

# ECHOTEL® 910

## Installation and Operating Manual



*Ultrasonic*

*Level*

*Switch*

## UNPACKING

Unpack the instrument carefully. Make sure all components have been removed from the foam protection. Inspect all components for damage. Report any concealed damage to the carrier within 24 hours. Check the contents of the carton/crates against the packing slip and report any discrepancies to Magnetrol. Check the nameplate model number to be sure it agrees with the packing slip and purchase order. Check and record the serial number for future reference when ordering parts.

Model and serial number

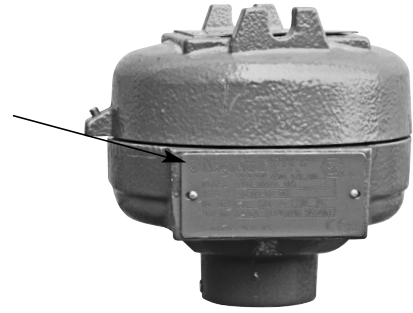

These units are in conformity with the provisions of:

1. The EMC Directive: 2014/32/EU. The units have been tested to EN 61326: 1997 + A1 + A2.
2. Directive 2014/34/EU for Equipment or protective system for use in potentially explosive atmospheres. EC-type examination certificate number ISSEP11ATEX002X. Standards applied: EN 60079-0: 2009, EN 60079-1: 2007, EN 60079-7: 2007, EN 60079-26: 2007.
3. The PED directive 97/23/EC (pressure equipment directive). Safety accessories per category IV module H1.

## MOUNTING

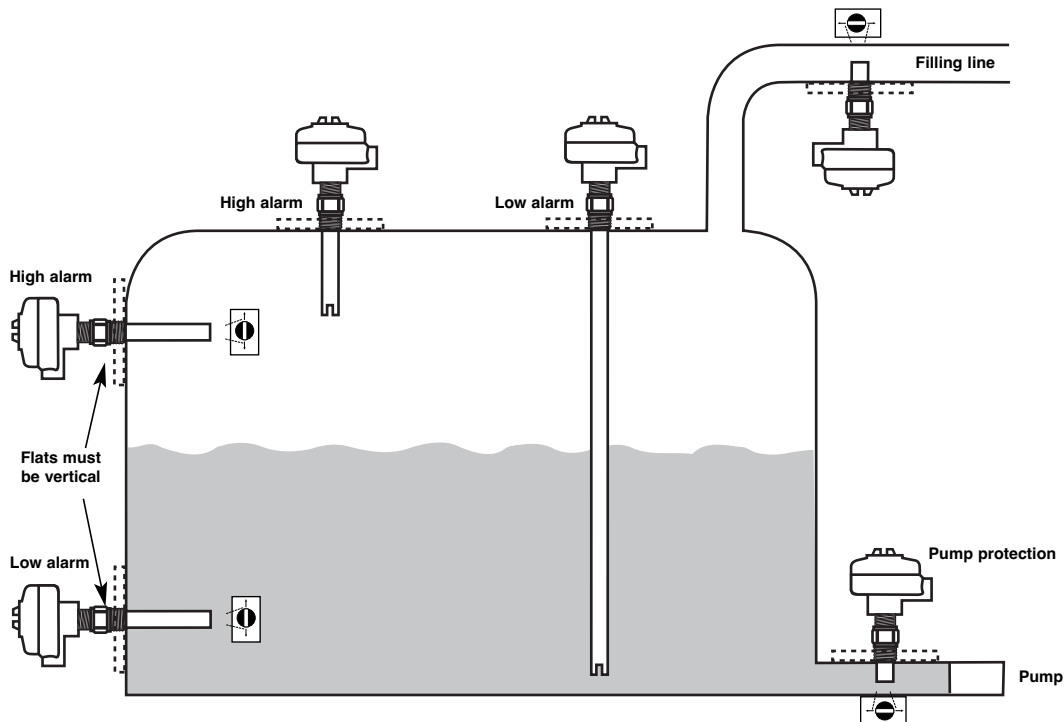

Nozzle mounting: gap must be free

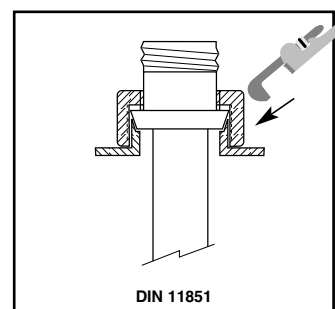
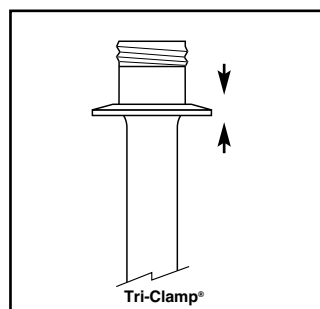
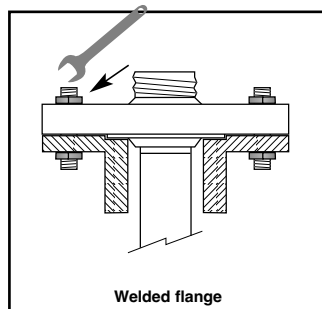
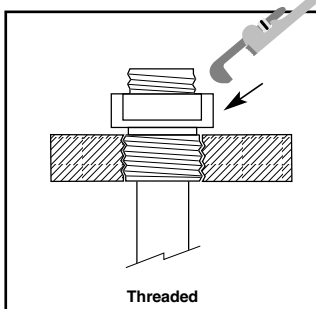
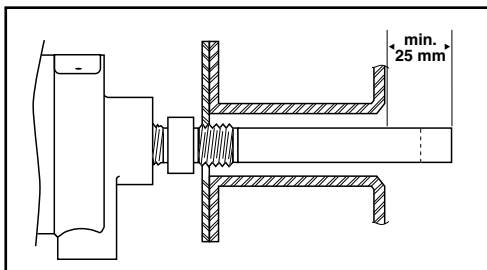

# WIRING

Sensor plugs  
(may be reversed)

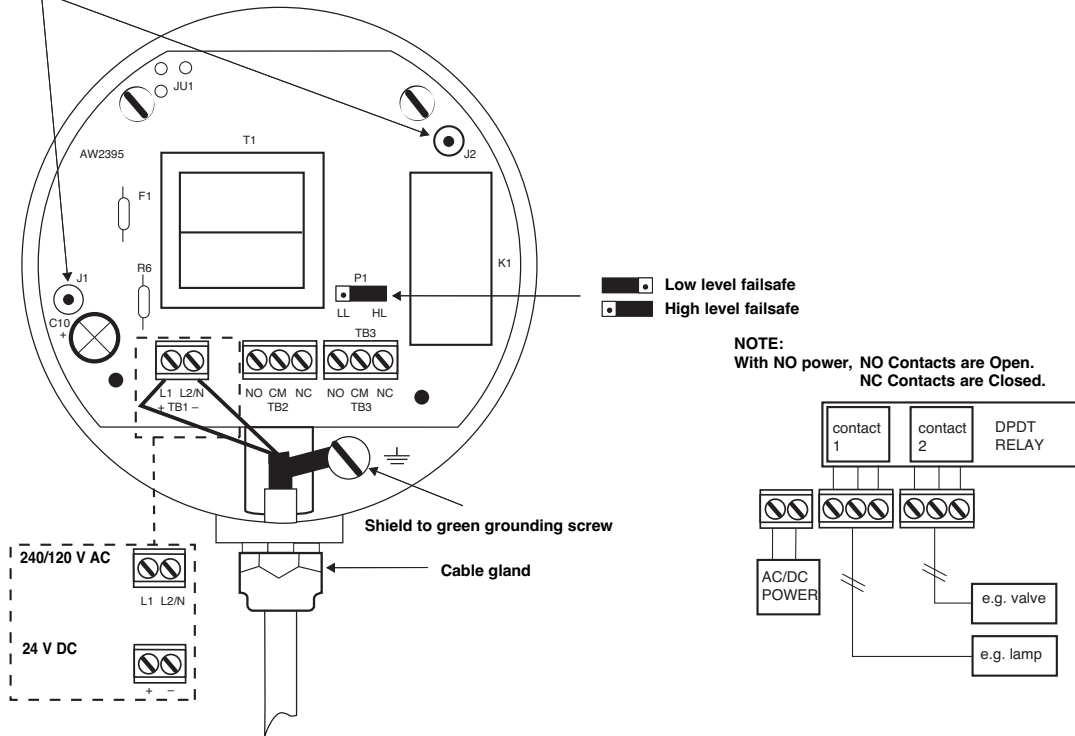

# FAILSAFE – ALARM STATUS

Mode	Level	Relay	Alarm status
«Hi» High level failsafe		Energized	No alarm
		De-energized	Alarm
«Lo» Low level failsafe		Energized	No alarm
		De-energized	Alarm

## SPECIFICATIONS

### PERFORMANCE

Description	Specification
Response time	0,5 s typical
Repeatability	± 2 mm (0.078")
Ambient Temperature	-40 °C up to +70 °C (-40 °F up to +160 °F)
Humidity	0-99 %, non-condensing
Electromagnetic Compatibility	Meets CE requirements (EN-61326: 1997 + A1 + A2)

### ELECTRONICS SPECIFICATIONS

Description	Specification
Line Voltage (±10%)	240/120 V AC, 50-60 Hz – 24 V DC
Power consumption	2.5 VA Nominal
Output Relay	Goldflash relay
	Hermetically sealed relay
Failsafe	Field selectable high or low level alarm
Housing	IP 65, anti-corrosive painted cast aluminium or 316 stainless steel
Approvals	ATEX II 1/2 G Ex d+e/d IIC T6 Ga/Gb, flameproof enclosure Other approvals are available, consult factory for more details

### TRANSDUCER SPECIFICATIONS

Description	Specification
Material	316/316L SST (1.4401/1.4404)
Mounting	Threaded (NPT/BSP) – Flanged (ANSI - EN (DIN)) – Hygienic (Tri-Clamp® / DIN 11851)
Actuation length	From 3 cm up to 254 cm (1.2" up to 100.0")
Operating process temp.	-40 °C up to +120 °C (-40 °F up to +250 °F)
Max pressure	55,1 bar @ +120 °C (800 psi @ +250 °F) Flanged models are downrated to the design pressure of the selected flange

### TEMPERATURE/PRESSURE RATING

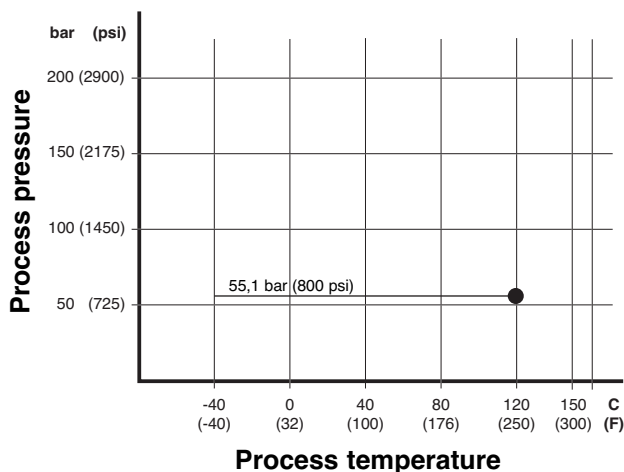



**Optional transducer mounting flanges**

Thread-on mounting flanges can only be used in combination with 3/4" NPT process connection transducer.

ANSI B16.5 flanges	Part No.	
	Carbon steel	316/316L SST
1" 150 lbs RF	004-5867-041	004-5867-043
1 1/2" 150 lbs RF	004-5867-021	004-5867-001
2" 150 lbs RF	004-5867-022	004-5867-002
3" 150 lbs RF	004-5867-023	004-5867-003
4" 150 lbs RF	004-5867-024	004-5867-004
6" 150 lbs RF	004-5867-025	004-5867-005
1" 300 lbs RF	004-5867-042	004-5867-044
1 1/2" 300 lbs RF	004-5867-026	004-5867-006
2" 300 lbs RF	004-5867-027	004-5867-007
3" 300 lbs RF	004-5867-028	004-5867-008
4" 300 lbs RF	004-5867-029	004-5867-009
6" 300 lbs RF	004-5867-030	004-5867-010
1" 600 lbs RF	004-5867-051	004-5867-050
1 1/2" 600 lbs RF	004-5867-046	004-5867-045
2" 600 lbs RF	004-5867-049	004-5867-048

**REPLACEMENT PARTS**

Partn°:

Serial n°:

Digit in partn°:  X  1  2  3  4  5  6  7  8  9  10

See nameplate, always provide complete partn° and serial n° when ordering spares.

X = product with a specific customer requirement

**EXPEDITE SHIP PLAN (ESP)**

Several parts are available for quick shipment, within max. 1 week after factory receipt of purchase order, through the Expedite Ship Plan (ESP).  
Parts covered by ESP service are conveniently grey coded in the selection tables.

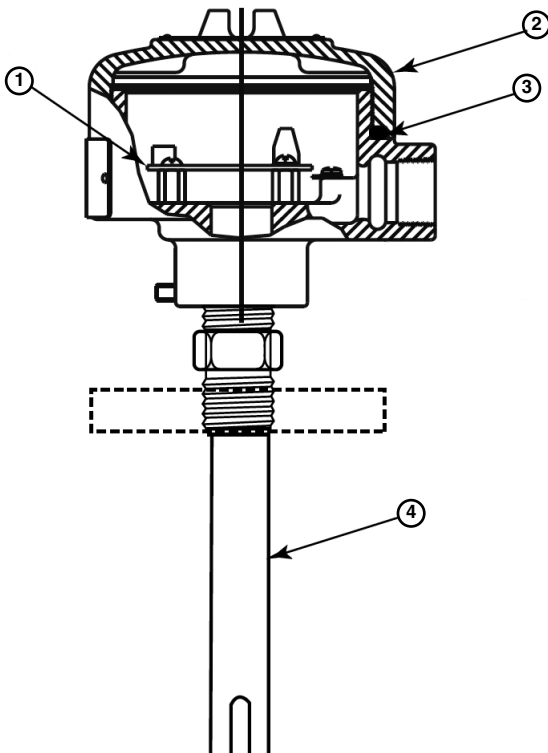

(1) PC board	
Digit 7	Replacement part
0	Z30-2043-003
1	Z30-2043-004
2	Z30-2043-002
H	Z30-2043-011
J	Z30-2043-012
K	Z30-2043-010

(2) Housing cover	
Digit 4	Replacement part
A	004-9105-001
V or W	004-9105-005
5	004-9142-003

	Replacement part
(3) "O"-ring	012-2101-345
(4) Transducer	consult factory

**DIMENSIONS IN mm (inches)**

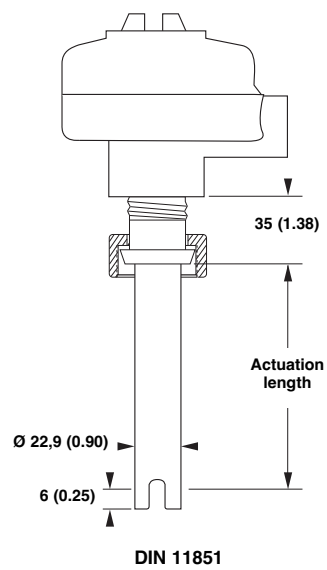
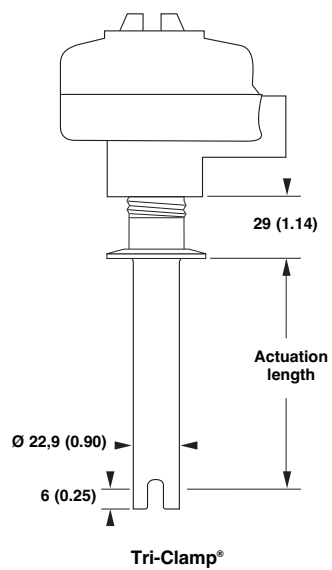
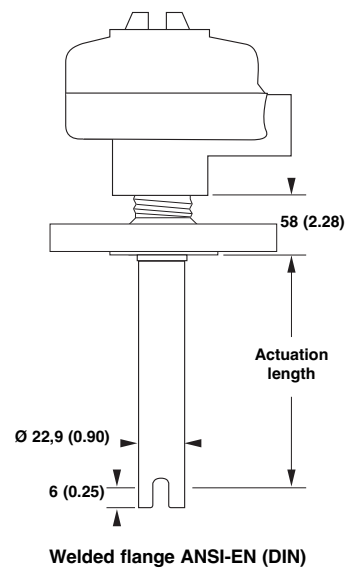
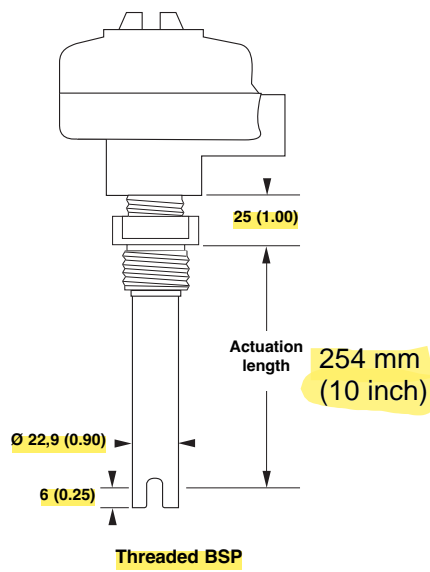
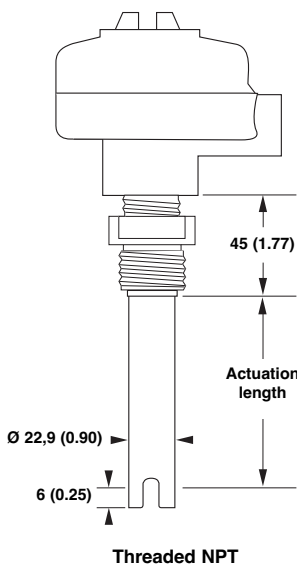
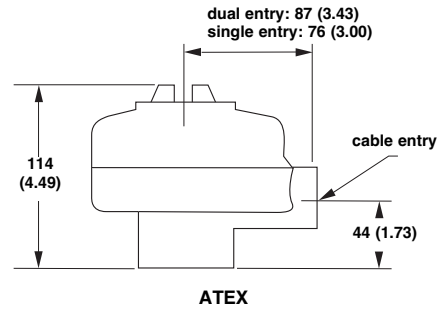
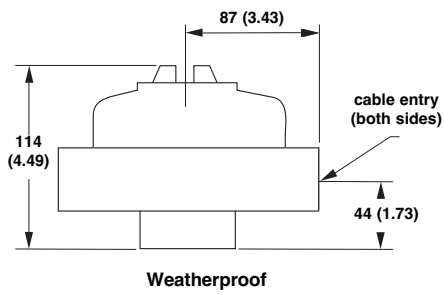

# IMPORTANT

## SERVICE POLICY

Owners of Magnetrol products may request the return of a control; or, any part of a control for complete rebuilding or replacement. They will be rebuilt or replaced promptly. Magnetrol International will repair or replace the control, at no cost to the purchaser, (or owner) **other than transportation cost** if:

- a. Returned within the warranty period; and,
- b. The factory inspection finds the cause of the malfunction to be defective material or workmanship.

If the trouble is the result of conditions beyond our control; or, is **NOT** covered by the warranty, there will be charges for labour and the parts required to rebuild or replace the equipment.

In some cases, it may be expedient to ship replacement parts; or, in extreme cases a complete new control, to replace the original equipment before it is returned. If this is desired, notify the factory of both the model and serial numbers of the control to be replaced. In such cases, credit for the materials returned, will be determined on the basis of the applicability of our warranty.

No claims for misapplication, labour, direct or consequential damage will be allowed.

## RETURNED MATERIAL PROCEDURE

So that we may efficiently process any materials that are returned, it is essential that a "Return Material Authorisation" (RMA) form will be obtained from the factory. It is mandatory that this form will be attached to each material returned. This form is available through Magnetrol's local representative or by contacting the factory. Please supply the following information:

1. Purchaser Name
2. Description of Material
3. Serial Number and Ref Number
4. Desired Action
5. Reason for Return
6. Process details

Any unit that was used in a process must be properly cleaned in accordance with the proper health and safety standards applicable by the owner, before it is returned to the factory.

A material Safety Data Sheet (MSDS) must be attached at the outside of the transport crate or box.

All shipments returned to the factory must be by prepaid transportation. Magnetrol **will not accept** collect shipments.

All replacements will be shipped Ex Works.

BULLETIN N°: BE 51-604.21  
EFFECTIVE: SEPTEMBER 2014  
SUPERSEDES: June 2012

UNDER RESERVE OF MODIFICATIONS



www.magnetrol.com

BENELUX FRANCE	Heikensstraat 6, 9240 Zele, België -Belgique Tel. +32 (0)52.45.11.11 • Fax. +32 (0)52.45.09.93 • E-Mail: info@magnetrol.be
DEUTSCHLAND	Alte Ziegelei 2-4, D-51491 Overath Tel. +49 (0)2204 / 9536-0 • Fax. +49 (0)2204 / 9536-53 • E-Mail: vertrieb@magnetrol.de
INDIA	B-506, Sagar Tech Plaza, Saki Naka Junction, Andheri (E), Mumbai - 400072 Tel. +91 22 2850 7903 • Fax. +91 22 2850 7904 • E-Mail: info@magnetrolindia.com
ITALIA	Via Arese 12, I-20159 Milano Tel. +39 02 607.22.98 • Fax. +39 02 668.66.52 • E-Mail: mit.gen@magnetrol.it
RUSSIA	198095 Saint-Petersburg, Marshala Govorova street, house 35A, office 427 Tel. +7-812.702.70.87 • E-Mail: info@magnetrol.ru
U.A.E.	DAFZA Office 5EA 722 • PO Box 293671 • Dubai Tel. +971-4-6091735 • Fax +971-4-6091736 • E-Mail: info@magnetrol.ae
UNITED KINGDOM	Unit 1 Regent Business Centre, Jubilee Road Burgess Hill West Sussex RH 15 9TL Tel. +44 (0)1444 871313 • Fax +44 (0)1444 871317 • E-Mail: sales@magnetrol.co.uk