

**STERI-TROL™ Aseptic Service 'S' Series
Pneumatic Two-port Control Valves****DN15 (1/2") to DN100 (4")**Installation and Maintenance Instructions

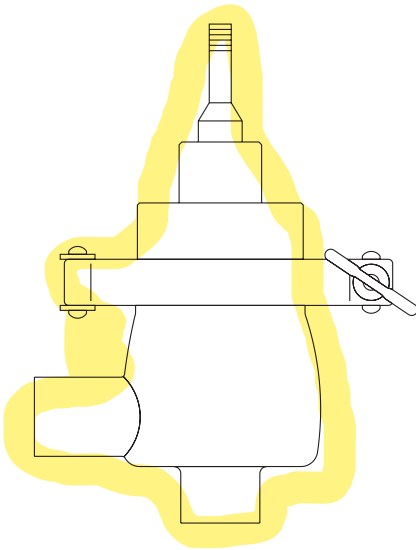

1. Safety information
2. General product information
3. Installation
4. Commissioning
5. Maintenance
6. Spare parts

1. Safety information

Safe operation of these products can only be guaranteed if they are properly installed, commissioned, used and maintained by qualified personnel (see Section 1.11) in compliance with the operating instructions. General installation and safety instructions for pipeline and plant construction, as well as the proper use of tools and safety equipment must also be complied with.

1.1 Intended use

Referring to the Installation and Maintenance Instructions, name-plate and Technical Information Sheet, check that the product is suitable for the intended use/application. The products listed below comply with the requirements of the Pressure Equipment Directive (PED), if required. The products fall within the following Pressure Equipment Directive categories:

		Product	Group 2 Gas	Group 2 Liquid
STERI-TROL™	PN16	DN15 to DN65	SEP	SEP
		DN80 to DN100	1	SEP

- i) The products have been specifically designed for use on steam, air, water, diathermic oil and/or other non-dangerous fluids which are in Group 2 of the above mentioned Pressure Equipment Directive.
- ii) Check material suitability, pressure and temperature and their maximum and minimum values. If the maximum operating limits of the product are lower than those of the system in which it is being fitted, or if a malfunction of the product could result in a dangerous overpressure or overtemperature occurrence, ensure a safety device is included in the system to prevent such over-limit situations.
- iii) Determine the correct installation situation and direction of fluid flow.
- iv) Spirax Sarco products are not intended to withstand external stresses that may be induced by any system to which they are fitted. It is the responsibility of the installer to consider these stresses and take adequate precautions to minimise them.
- v) Remove protection covers from all connections and protective film from all name-plates, where appropriate, before installation on steam or other high temperature applications.

1.2 Access

Ensure safe access and if necessary a safe working platform (suitably guarded) before attempting to work on the product. Arrange suitable lifting gear if required.

1.3 Lighting

Ensure adequate lighting, particularly where detailed or intricate work is required.

1.4 Hazardous liquids or gases in the pipeline

Consider what is in the pipeline or what may have been in the pipeline at some previous time. Consider: flammable materials, substances hazardous to health, extremes of temperature.

1.5 Hazardous environment around the product

Consider: explosion risk areas, lack of oxygen (e.g. tanks, pits), dangerous gases, extremes of temperature, hot surfaces, fire hazard (e.g. during welding), excessive noise, moving machinery.

1.6 The system

Consider the effect on the complete system of the work proposed. Will any proposed action (e.g. closing isolation valves, electrical isolation) put any other part of the system or any personnel at risk?

Dangers might include isolation of vents or protective devices or the rendering ineffective of controls or alarms. Ensure isolation valves are opened and closed gradually to avoid shocks to the system.

1.7 Pressure systems

Ensure that any pressure is isolated and safely vented to atmospheric pressure. Consider double isolation (double block and bleed) and the locking or labelling of closed valves. Do not assume that the system has depressurised even when the pressure gauge indicates zero.

1.8 Temperature

Allow time for temperature to normalise after isolation to avoid danger of burns.

1.9 Tools and consumables

Before starting work ensure that you have suitable tools and/or consumables available. Use only genuine Spirax Sarco replacement parts.

1.10 Protective clothing

Consider whether you and/or others in the vicinity require any protective clothing to protect against the hazards of, for example, chemicals, high/low temperature, radiation, noise, falling objects, and dangers to eyes and face.

1.11 Permits to work

All work must be carried out or be supervised by a suitably competent person. Installation and operating personnel should be trained in the correct use of the product according to the Installation and Maintenance Instructions.

Where a formal 'permit to work' system is in force it must be complied with. Where there is no such system, it is recommended that a responsible person should know what work is going on and, where necessary, arrange to have an assistant whose primary responsibility is safety.

Post 'warning notices' if necessary.

1.12 Handling

Manual handling of large and /or heavy products may present a risk of injury. Lifting, pushing, pulling, carrying or supporting a load by bodily force can cause injury, particularly to the back. You are advised to assess the risks taking into account the task, the individual, the load and the working environment and use the appropriate handling method according to the circumstances of the work being done.

1.13 PTFE - Handling precautions

Within its working temperature range PTFE is a completely inert material, but when heated to its sintering temperature it gives rise to a gaseous decomposition product or fumes which can produce unpleasant effects if inhaled. The inhalation of these fumes is easily prevented by applying local exhaust ventilation to atmosphere as near to their source as possible.

Smoking should be prohibited in workshops where PTFE is handled because tobacco contaminated with PTFE will during burning give rise to polymer fumes. It is therefore important to avoid contamination of clothing, especially the pockets, with PTFE and to maintain a reasonable standard of personal cleanliness by washing hands and removing any PTFE particles lodged under the fingernails.

1.14 Residual hazards

In normal use, the external surface of the product may be very hot. If used at the maximum permitted operating conditions the surface temperature of some products may reach temperatures of 200 °C (392 °F).

Many products are not self-draining. Take due care when dismantling or removing the product from an installation (See Section 5, 'Maintenance').

1.15 Freezing

Provision must be made to protect products which are not self-draining against frost damage in environments where they may be exposed to temperatures below freezing point.

1.16 Disposal

Unless otherwise stated in the Installation and Maintenance Instructions, this product is recyclable and no ecological hazard is anticipated with its disposal providing due care is taken. However, if the valve is fitted with a Viton or PTFE seat, special care must be taken to avoid potential health hazards associated with decomposition/burning of these seats.

Viton:

- Can be landfilled, when in compliance with National and Local regulations.
- Can be incinerated, but a scrubber must be used to remove Hydrogen Fluoride, which is evolved from the product and with compliance to National and Local regulations.
- Is insoluble in aquatic media.

PTFE:

- Can only be disposed of by approved methods, not incineration.
- Keep PTFE waste in a separate container, do not mix it with other rubbish, and consign it to a landfill site.

1.17 Returning products

Customers and stockists are reminded that under EC Health, Safety and Environment Law, when returning products to Spirax Sarco they must provide information on any hazards and the precautions to be taken due to contamination residues or mechanical damage which may present a health, safety or environmental risk. This information must be provided in writing including Health and Safety data sheets relating to any substances identified as hazardous or potentially hazardous.

2. General product information

2.1 Description

STERI-TROL™ 'S' series are 316L stainless steel, two-port and three-port control valves. They are designed for mixing/diverting fluids (three-port only), and for on/off and modulating control of clean steam, pure steam and process fluids. The valve is operated by a pneumatic actuator and may be interfaced with a control system using any of the Spirax Sarco range of positioners.

Available types	SB	Two-port angle pattern design with aseptic steam sanitised bonnet
	SA	Two-port angle pattern design (for chemical free steam)
Valve characteristics - options	SAE SBE	Equal percentage (E) - Suitable for most modulating process control applications and good control at low flowrates.
	SAL SBL	Linear (L) - Primarily for liquid flow control where the differential pressure across the valve is constant.

Important note: Throughout this document, reference has been made to the standard SAE control valve. With the exception of the trim type and porting arrangement, the SAE, SBE, SAL and SBL control valves are virtually identical.

Approvals and certification

Compliant to ASME BPE SF4 2019, internal surface finish 0.375 µm.

FDA, 3A and USP 26 Class VI approved sealing materials.

EN 10204 type 3.1 certificates supplied as standard.

Surface finish certificate supplied as standard.

Valve seating - options	S	Metal-to-metal (as standard) - Stainless steel
	V	Soft seal - White Viton to provide a tight shut-off
Valve stem sealing - options	V	White Viton - 3A, FDA and USP 26 Class VI approved

The STERI-TROL™ can be used with the following actuators

Electric	Electric actuators available on request
Pneumatic	PNS3000, PNS4000, PN9000E and PN9000R series

Refer to the relevant actuator Technical Information sheet for further details.

Note: For further product data regarding the STERI-TROL 'S' series see the Technical Information Sheet

2.2 Technical data

Plug design	DN15 to DN100	Parabolic
Leakage	Metal-to-metal	(0.01% of Kv)
	Soft seal	IEC 534-4 Class VI
Rangeability	Equal percentage	50:1
	Linear	30:1
Travel	DN15 to DN50 (½" to 2")	20 mm
	DN65 to DN100 (2½" to 4")	30 mm
Surface finish	Internal (Mechanical or electropolished)	0.4 µ
	External	< 0.6 µ

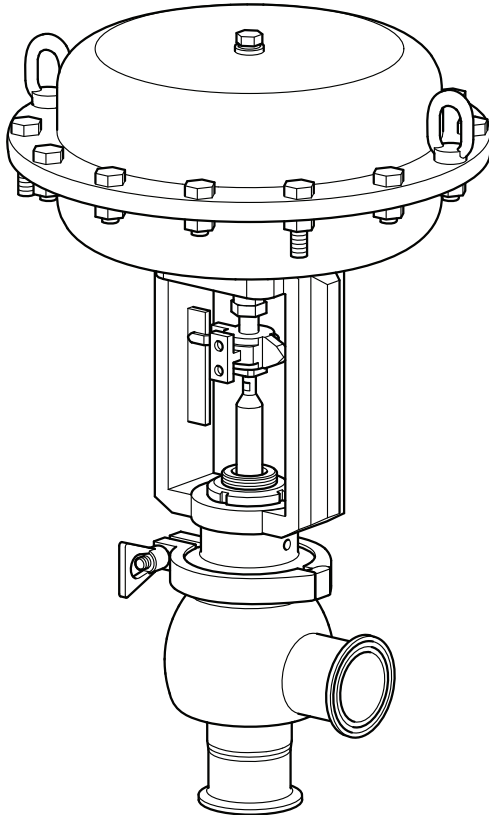
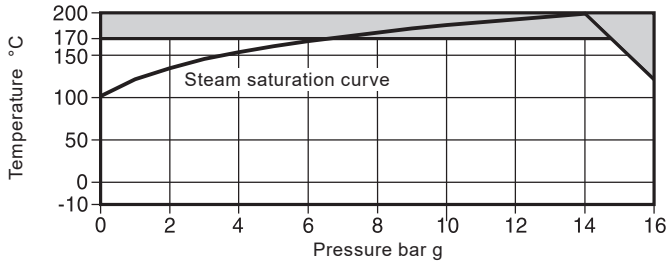

Fig. 1

STERI-TROL™ Aseptic Service 'S' Series Two-port Pneumatic Control Valves - DN15 (½") to DN100 (4")

2.3 Pressure / temperature limits



The product **must not** be used in this region.

Body design conditions	PN16
Maximum design pressure	16 bar g @ 120 °C
Maximum design temperature	200 °C @ 14 bar g
Minimum design temperature	-20 °C
Maximum operating temperature	Viton (FKM) (V) 170 °C
Minimum operating temperature	-10 °C
Note: For lower operating temperatures consult Spirax Sarco.	
Maximum differential pressure	See pages 6 to 7
Designed for a maximum cold hydraulic test pressure of:	24 bar g

3. Installation

Note: Before actioning any installation observe the 'Safety information' in Section 1.

Referring to the Installation and Maintenance Instructions, name-plate and Technical Information Sheet, check that the product is suitable for the intended installation:

- 3.1** Check materials, pressure and temperature and their maximum values. **Do not exceed the performance rating of the valve.** If the maximum operating limit of the product is lower than that of the system in which it is being fitted, ensure that a safety device is included in the system to prevent overpressurisation.
- 3.2** Remove protection covers from all connections and protective film from all name-plates, where appropriate, before installation on steam or other high temperature applications.
- 3.3** Determine the correct installation situation and the direction of fluid flow. Valves will have fluid flow from the lower port. The valve should preferably be installed along a pipeline, slightly declined in the direction of flow, to ensure complete drainability of the valve body. When mounting an actuator to the valve body, the actuator Installation and Maintenance Instructions must be followed.
- 3.4** **Bypass arrangements** - It is recommended that isolating valves be fitted upstream and downstream of the control valve, together with a manual bypass control valve. This enables the process to be controlled manually using the bypass valve while the pneumatic valve is isolated for maintenance.
- 3.5** Support pipework should be used to prevent stresses being exerted on the valve body.
- 3.6** Ensure adequate space is provided for the removal of the actuator from the valve body for maintenance purposes:
- 3.7** Isolate connecting pipework. Ensure it is clean from dirt, scale etc. Any debris entering the valve may damage the PTFE head seal preventing a tight shut-off.
- 3.8** Open isolation valves slowly, until normal operating conditions are achieved.
- 3.9** Check for leaks and correct operation.

4. Commissioning

Ensure all pipework is free from dirt after the process pipework has been constructed.

- 4.1** Make certain the valve actuator is in the correct position and connected up to the air or mains supply before the system is energised.
- 4.2** If the motive supply is air it must be dry, clean and free from oil contamination. This is particularly important where a pneumatic positioner is used.
- 4.3** Should an electric actuator be required then all electrical wiring and connections should be carried out in accordance with national or local regulations and standards.
- 4.4** Turn on the process fluid slowly and look for any leaks from connections.

5. Maintenance

Note: Before actioning any maintenance programme observe the 'Safety information' in Section 1.

5.1 Periodic maintenance

After 24 hours of operation	After 24 hours of operation check the piping connections for tightness.
Every 3 months of operation	Every 3 months of normal operation visually check the gland seal for signs of leakage.
Annually	Inspect the valve to check for wear or scale deposits, replacing any worn or damaged parts, such as the plug or stem or gland seal. Please see Section 6, for a list of available spare parts.

5.2 Procedure for replacing the stem packing and the stem/plug

Warning: Please acknowledge the 'Safety information' in Section 1 regarding the handling and disposal of PTFE and Viton parts.

Reference Figures 2 and 3:

- Isolate the valve on both sides.
- Remove the actuator from the valve. Refer to the Installation and Maintenance Instructions covering Spirax Sarco actuators.
- Remove the bottom adaptor (19).
- Remove the body clamp (32), lift the bonnet (27) and free the stem (26) from the bonnet. **Caution:** Care should be taken when removing the cover since fluid under pressure may be trapped between the isolating valves.
- Remove the seals (29, 30 and 31).
- Examine parts for any signs of damage and/or wear. Score marks or scaly deposits on the valve stem (26) could damage the seals, and it should therefore be replaced. Fit the new seals (29, 30 and 31) after liberally smearing them with the appropriate FDA approved oil.
- Clean the parts taking care to avoid scratching the stem (26) or the packing chamber. Refit the cleaned or replacement valve stem and plug.
- Using a new bonnet seal (28), replace the bonnet (27) on the valve body (if it is the SH valve which is being serviced, also replace the body seal (28)), leaving the stem protruding. Tighten the body clamp (32).
- Ensure the valve stem (26) can move freely.
- Refit the bottom adaptor (19).
- Refit the actuator, following the relative assembly instructions.
- Bring the valve back into service. Open the isolation valves and check for leaks.

**PNS4000 series
actuator**

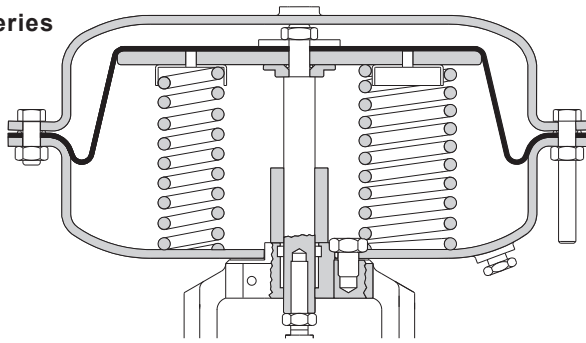

**PNS3000 series
actuator**

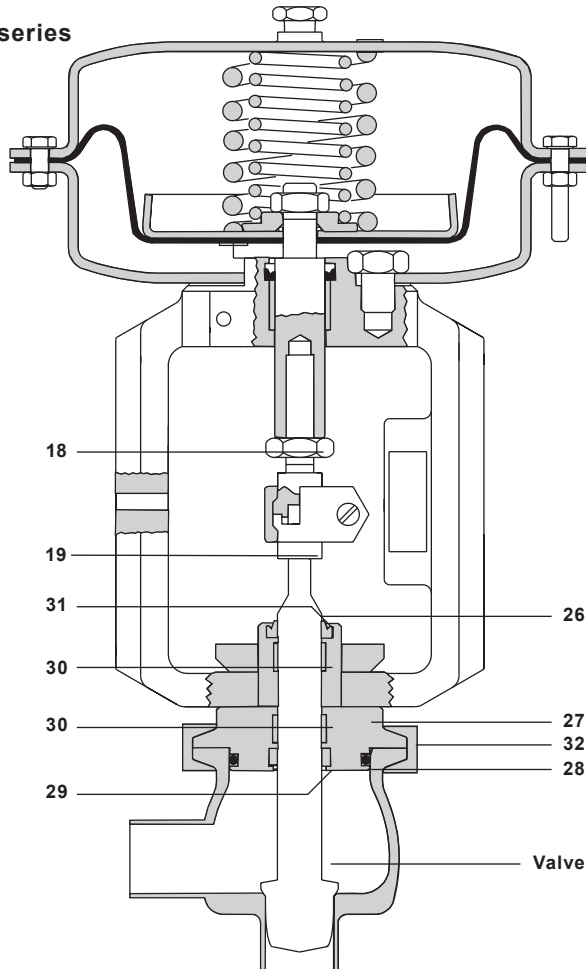

Fig. 3 Actuator and SA valve

6. Spare parts

Spare parts

The available spares are identified by the part numbers listed below. When placing an order for spare parts, always specify the actuator or the valve model (shown on the data plate) and the name of the part as described below.

Available spares

		Description				
Actuator		Stem seal kit	('O' ring and 'V' ring)		8 and 12	
		Diaphragm kit	(diaphragm 'O' ring and 'V' ring)		2, 8 and 12	
		Travel indicator				22
		Spring kit	(set of springs, included 3 off longer hex, head bolts and nut on some spring range)			4 and 16
		Linkage kit	(lock-nut, top adaptor connectors, bolts and nuts)			17, 18, 19, 20 and 21
Valve	SA and SB models	Valve stem seal set (excluding bonnet seal)			29, 30 and 31	
		Bonnet seal	Viton	(packet of 3)	28	
		Plug and stem	(Equal percentage or Linear)		26	

Spare parts ordering example:

1 off Valve stem seal set for a STERI-TROL™ DN15 SBE6OOSV04 two-port control valve.

1 off Stem seal kit for a type PNS3320 pneumatic actuator having a spring range 0.4 to 1.2 bar.

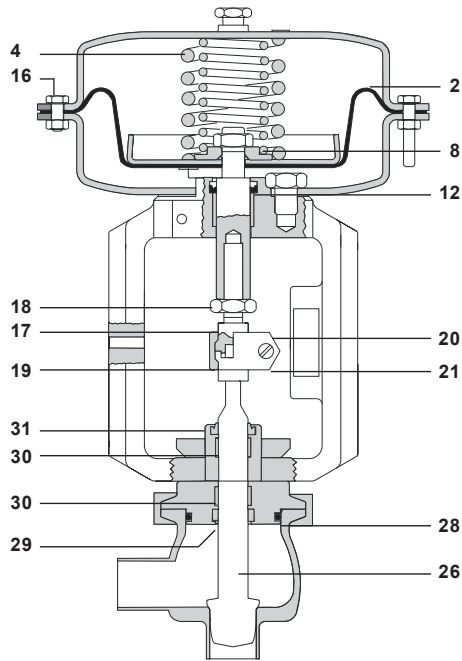

Fig. 4 Actuator and SA valve

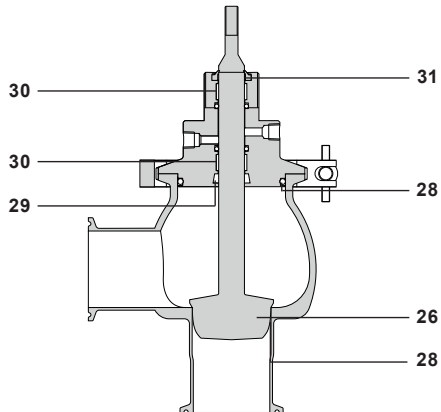

Fig. 5

SB 2-Port control valve with aseptic steam sanitized bonnet (Provided as standard)

