

**Model 621ED Differential (MWP 14 MPa)**

**Model 621EE Differential (MWP 25 MPa)**

**Model 621EH Differential (high vacuum)**

**Model 621EG Gauge**

**Model 621EA Absolute**

- **Base accuracy :  $\pm 0.075\%$**
- **Reliable inductive sensing system coupled with the very latest digital technologies**
  - ensures high performance at all process conditions
- **Wide selection of materials and choice of fill fluids including "process-inert"**
  - meet virtually all process requirements also protecting application integrity
- **HART 4-20 mA, Profibus PA, FF versions with plug-and-play electronics replacement**
  - provides interchangeability for upgrading transmitter
- **Local snap calibration and full management via hand terminal or PC-running software**
- **HART®, Profibus PA, FF communications**
  - allows integration with standard process bus
- **CoMeter display option**
  - offers HART Configuration capabilities combined with local indication
- **Ecoefficient life cycle**
  - ensures low environmental impact in compliance with LCA assessment to ISO 14040 standard

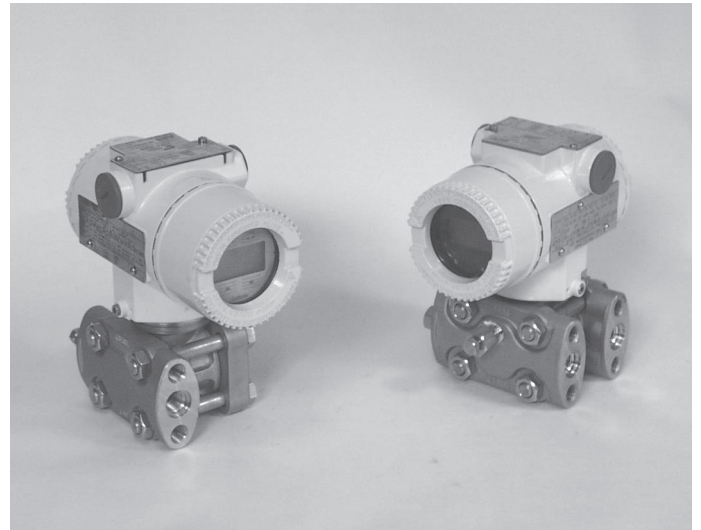

***The all new 600T Series transmitter  
The first choice pressure transmitter is  
now an even bigger choice***

# FUNCTIONAL SPECIFICATIONS

## Range and span limits

| Sensor code | Upper Range Limit (URL)                        | Lower Range Limit (LRL)                              |  |  |   |  | Turndown ratio (TD) |          |         |           |          |         |
|-------------|--|--|--|--|---|--|---------------------|----------|---------|-----------|----------|---------|
|             |  | 621ED Differential                                   | 621EE Differential                                   | 621EH Differential                                   | 621EG Gauge   | 621EA Absolute                           | 621ED, EE, EG       |          |         | 621EH, EA |          |         |
|             |  | MWP 14 MPa   | MWP 25 MPa   | high vacuum  |   |  | Normal              | Extended | Maximum | Normal    | Extended | Maximum |
| <b>A</b>    | 2.5 kPa<br>25 mbar<br>10 inH <sub>2</sub> O    | - 2.5 kPa<br>- 25 mbar<br>- 10 inH <sub>2</sub> O    |  |  |   |  | 10                  | 20       | 30      |           |          |         |
| <b>B</b>    | 10 kPa<br>100 mbar<br>40.1 inH <sub>2</sub> O  | - 10 kPa<br>- 100 mbar<br>- 40.1 inH <sub>2</sub> O  |  | - 10 kPa<br>- 100 mbar<br>- 40.1 inH <sub>2</sub> O  | - 10 kPa<br>- 100 mbar<br>- 40.1 inH <sub>2</sub> O | 0.07 kPa abs<br>0.7 mbar abs<br>0.5 mmHg | 10                  | 20       | 30      | 5         | 10       | 30      |
| <b>C</b>    | 40 kPa<br>400 mbar<br>160 inH <sub>2</sub> O   | - 40 kPa<br>- 400 mbar<br>- 160 inH <sub>2</sub> O   |  | - 40 kPa<br>- 400 mbar<br>- 160 inH <sub>2</sub> O   | - 40 kPa<br>- 400 mbar<br>- 160 inH <sub>2</sub> O  | 0.07 kPa abs<br>0.7 mbar abs<br>0.5 mmHg | 15                  | 60       | 100     | 10        | 20       | 60      |
| <b>N</b>    | 65 kPa<br>650 mbar<br>260 inH <sub>2</sub> O   | - 65 kPa<br>- 650 mbar<br>- 260 inH <sub>2</sub> O   | - 65 kPa<br>- 650 mbar<br>- 260 inH <sub>2</sub> O   | - 65 kPa<br>- 650 mbar<br>- 260 inH <sub>2</sub> O   | - 65 kPa<br>- 650 mbar<br>- 260 inH <sub>2</sub> O  | 0.07 kPa abs<br>0.7 mbar abs<br>0.5 mmHg | 15                  | 60       | 100     | 10        | 20       | 60      |
| <b>D</b>    | 160 kPa<br>1600 mbar<br>642 inH <sub>2</sub> O | - 160 kPa<br>- 1600 mbar<br>- 642 inH <sub>2</sub> O | - 160 kPa<br>- 1600 mbar<br>- 642 inH <sub>2</sub> O | - 160 kPa<br>- 1600 mbar<br>- 642 inH <sub>2</sub> O | 1 kPa abs<br>10 mbar abs<br>0.15 psia               | 0.07 kPa abs<br>0.7 mbar abs<br>0.5 mmHg | 15                  | 60       | 100     | 10        | 20       | 60      |
| <b>E</b>    | 600 kPa<br>6 bar<br>87 psi                     | - 600 kPa<br>- 6 bar<br>- 87 psi                     | - 600 kPa<br>- 6 bar<br>- 87 psi                     |  | 1 kPa abs<br>10 mbar abs<br>0.15 psia               | 0.07 kPa abs<br>0.7 mbar abs<br>0.5 mmHg | 15                  | 60       | 100     | 10        | 20       | 60      |
| <b>F</b>    | 2400 kPa<br>24 bar<br>348 psi                  | - 2400 kPa<br>- 24 bar<br>- 348 psi                  | - 2400 kPa<br>- 24 bar<br>- 348 psi                  |  | 1 kPa abs<br>10 mbar abs<br>0.15 psia               | 0.07 kPa abs<br>0.7 mbar abs<br>0.5 mmHg | 15                  | 60       | 100     | 10        | 20       | 60      |
| <b>W</b>    | 8000 kPa<br>80 bar<br>1160 psi                 | - 8000 kPa<br>- 80 bar<br>- 1160 psi                 | - 8000 kPa<br>- 80 bar<br>- 1160 psi                 |  | 1 kPa abs<br>10 mbar abs<br>0.15 psia               | 0.07 kPa abs<br>0.7 mbar abs<br>0.5 mmHg | 15                  | 60       | 100     | 10        | 20       | 60      |
| <b>U</b>    | 16000 kPa<br>160 bar<br>2320 psi               |  | - 16000 kPa<br>- 160 bar<br>- 2320 psi               |  | 1 kPa abs<br>10 mbar abs<br>0.15 psia               | 0.07 kPa abs<br>0.7 mbar abs<br>0.5 mmHg | 15                  | 60       | 100     | 10        | 20       | 60      |

## Span limits

Maximum span = URL  
(can be further adjusted up to  $\pm$  URL (TD = 0.5) for differential models, within the range limits)  
Minimum recommended span = URL/TD extended  
(can be further turndown to URL/TD maximum at no stated performances)

## Zero suppression and elevation

Zero and span can be adjusted to any value within the range limits detailed in the table as long as:  
- calibrated span  $\geq$  minimum span

## Damping

Selectable time constant : 0, 0.25, 0.5, 1, 2, 4, 8 or 16 sec.

## Volume of process chamber

9 cm<sup>3</sup> approx (0.55 in<sup>3</sup>)

## Volumetric displacement

< 0.020 cm<sup>3</sup> (0.0015 in<sup>3</sup>) for max span.

## Electromagnetic compatibility (EMC)

Comply with EN 50081-2 for emission and EN 50082-2 for immunity requirements and test; CE marking.

## Turn on time

Operation within specification in less than 2 sec. with minimum damping.

## Insulation resistance

> 100 M $\Omega$  @ 1000 Vdc (terminals to earth)

## Temperature limits °C (°F) :

- Ambient (is the operating temperature)

| Filling      | Models 621ED, EE, EG          |                               | Models 621EH, EA              |                              |
|--------------|-------------------------------|-------------------------------|-------------------------------|------------------------------|
|              | Sensor C to U                 | Sensor A and B                | Sensor C to U                 | Sensor code B                |
| Silicone oil | -40 and +85<br>(-40 and +185) | -25 and +85<br>(-13 and +185) | -40 and +85<br>(-40 and +185) | -15 and +70<br>(+5 and +158) |
| Inert        | -20 and +85<br>(-4 and +185)  | -10 and +85<br>(+14 and +185) | -10 and +65<br>(+14 and +150) |                              |
| KTFILL-1     | -40 and +85<br>(-40 and +185) | -10 and +85<br>(+14 and +185) | -10 and +85<br>(+14 and +185) |                              |

Lower ambient limit for LCD indicators: -20°C (-4°F)

Upper ambient limit for CoMeter : +70°C (+158°F)

## • Process (1)

### Lower limit

- refer to lower ambient limits

- -20°C (-4°F) for Viton gaskets

Upper limit

- Silicone oil and KTFILL-1 filling : 120°C (248°F) (2)

- Inert fluid filling : 100°C (212°F) (3)

- (1) Process temperature above 85°C (185 °F) requires derating the ambient limits by 1.5 : 1 ratio.
- (2) 100°C (212°F) for application below atmospheric pressure
- (3) 65°C (150°F) for application below atmospheric pressure

## • Storage

Lower limit : -50°C (-58°F); -40°C (-40°F) for LCD indicators

Upper limit : +120°C (+248°F); +85°C (+185°F) for LCD indicators

**Overpressure limits** (without damage to the transmitter)

- Lower : 0.067 kPa abs, 0,67 mbar abs, 0.01 psia (0.13 kPa abs, 1.33 mbar abs, 0.02 psia for sensor code A). Double the lower limit with inert filling
- Upper
  - model 621ED, EG, EA  
sensor codes B to W : 14 MPa, 140 bar, 2030 psi  
sensor code A : 8 MPa, 80 bar, 1160 psi  
sensor code U : 25 MPa, 250 bar, 3620 psi
  - model 621EE :  
all sensor codes : 25 MPa, 250 bar, 3620 psi
  - model 621EH :  
all sensor codes : 1 MPa, 10 bar, 145 psi

**Static pressure**

Transmitters for differential pressure operate within specifications between the following limits

- model 621ED
  - sensor codes B to W :  
1.3 kPa abs, 13 mbar abs, 0.2 psia and 14 MPa, 140 bar, 2030 psi
  - sensor code A :  
2.5 kPa abs, 25 mbar abs, 0.4 psia and 8 MPa, 80 bar, 1160 psi
- model 621EE :  
all sensor codes :  
1.3 kPa abs, 13 mbar abs, 0.2 psia and 25 MPa, 250 bar, 3620 psi
- model 621EH:  
all sensor codes :  
0.067 kPa abs, 0.67 mbar abs, 0.01 psia and 1 MPa, 10 bar, 145 psi  
Double the lower limit with inert filling

**Proof pressure**

The transmitter meets SAMA PMC 27.1 requirements and can be exposed without leaking to line pressure of up to 48 MPa, 480 bar, 6960 psi (up to 28 MPa, 280 bar, 4060 psi for 621EG, 621EA)

**ELECTRICAL CHARACTERISTICS AND OPTIONS**

**• HART digital communication and 4 to 20 mA output**

**Power Supply**

The transmitter operates from 10.5 to 42 Vdc with no load and is protected against reverse polarity connection (additional load allows operations over 42 Vdc).

For EEx ia and intrinsically safe (FM, CSA and SAA) approval power supply must not exceed 30 Vdc.

**MINIMUM OPERATING VOLTAGES**

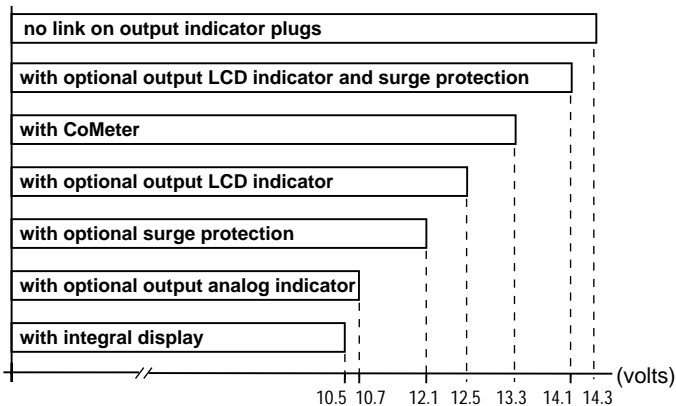

**Load limitations - 4-20 mA and HART total loop resistance :**

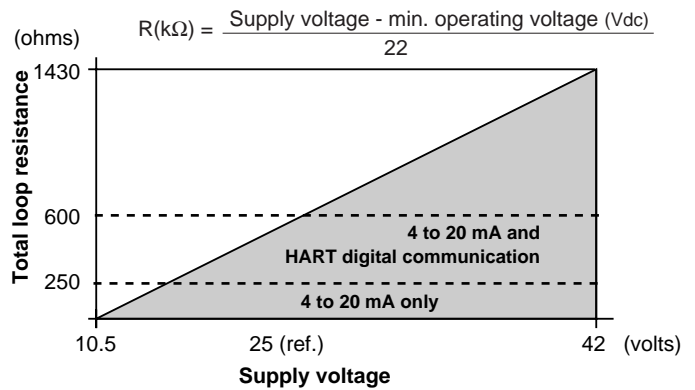

**Optional indicators**

- **Output meter (user adjustable)**
  - LCD : 3 1/2-digit with 10 mm (3/8 in) high, 7-segment characters. Engineering unit labels are provided. LCD output meter may be calibrated within the range -1999 to +1999 with a span adjustable between 100 and 3998 units. (Display of decimal point, if required, is switch selectable)
  - analog : 36 mm (1.4 in) scale on 90°
- **Integral display**
  - LCD: 4-digit with 8 mm. (5/16 in) high, 9-segment alphanumeric characters.
  - User-definable display mode with HART communication :
    - process variable in engineering units, or
    - percent of range, or
    - process variable in engineering units and percent of range alternating every 3 seconds, or
    - process variable in engineering units and digital output (4 to 20 mA) alternating every 3 seconds.
  - Factory selectable display mode with 4 to 20 mA output :
    - percent of range
    - percent of range and 4 to 20 mA output alternating every 3 seconds
  - Display also indicates diagnostic messages.
- **CoMeter**
  - 5-digit (±99999 counts) programmable with 7.6 mm. high (3 in), 7-segment numeric characters plus sign and digital point
  - 10-segment bargraph display (10% per segment)
  - 7-digit LCD with 6 mm. high (2.3 in), 14-segment alphanumeric characters.

**Optional surge protection**

Up to 2.5 kV (5 kA discharge current) of 8 μs rise time/20 μs decay.

**Output signal**

Two-wire 4 to 20 mA dc, user-selectable for linear or square root output, power of 3/2 or 5/2, 5th order or two 2nd order switching point selectable programmable polynomial output.

HART® communication provides digital process variable (% , mA or engineering units) superimposed on 4 to 20 mA signal, with protocol based on Bell 202 FSK standard.

**Output current limits (to NAMUR standard)**

- Overload condition
  - Lower limit : 3.8 mA dc
  - Upper limit : 20.8 mA dc

**Transmitter failure mode (to NAMUR standard)**

The output signal can be user-selected to a value of 3.6 or 21.6 mA on gross transmitter failure condition, detected by self-diagnostics.

In case of CPU failure the output is driven <3.6 mA or >21.6 mA.

- **Profibus PA output**

**Power supply**

The transmitter operates from 10.5 to 32 Vdc with no polarity. For EEx ia approval power supply must not exceed 15 Vdc. Intrinsic safety installation according to FISCO model.

**Current consumption**

- operating (quiescent) : 10.5 mA
- communicating : 20.5 mA
- fault current limiting : 16 mA max.

**Output signal**

Physical layer in compliance to IEC 1158-2/EN 61158-2 with transmission to Manchester II modulation, at 31.25 kbit/sec.

**Output interface**

Profibus PA communication according to Profibus DP50170 Part 2/DIN 19245 part 1-3 compliant to Profiles 3.0 Class A & B for pressure transmitter; ident. number 052B HEX.

**Output update time** : 25 ms

**Function blocks**

2 analog input, 1 transducer, 1 physical

**Optional indicator**

Integral display  
- LCD : 4 digit characters, displaying process variable in engineering units or as percentage value.  
Display also indicates diagnostic messages.

**Transmitter failure mode**

On gross transmitter failure condition, detected by self-diagnostics, the output signal can be driven to defined conditions, selectable by the user as safe, last valid or calculated value.

- **FOUNDATION fieldbus output**

**Device type**

Link Active Scheduler (LAS) capability implemented

**Power supply**

The transmitter operates from 9 to 32 Vdc with no polarity. For EEx ia approval power supply must not exceed 24 Vdc. Intrinsic safety installation according to FF application guide

**Current consumption**

- operating (quiescent) : 10.5 mA
- communicating : 20.5 mA
- fault current limiting : 16 mA max.

**Output signal**

Physical layer in compliance to IEC 1158-2/EN 61158-2 with transmission to Manchester II modulation, at 31.25 kbit/sec.

**Function blocks/execution period**

2 standard Analog Input blocks / 25 msec. max (each)  
1 standard PID block / 70 msec. max.

**Additional blocks**

Transducer block, 1 standard Resource block,  
1 custom Pressure with calibration block

**Number of link objects** : 25

**Number of VCRs** : 24

**Output interface**

FOUNDATION fieldbus digital communication protocol to standard H1, compliant to specification V. 1.4; FF registration IT011000.

**Optional indicator**

Integral display  
- LCD : 4 digit characters, displaying process variable in engineering units or as percentage value.  
Display also indicates diagnostic messages.

**Transmitter failure mode**

The output signal is "frozen" to the last valid value on gross transmitter failure condition, detected by self-diagnostics which also indicate a BAD conditions. If electronic failure or short circuit occur the transmitter consumption is electronically limited at a defined value (16 mA approx), for safety of the network.

**PERFORMANCE SPECIFICATIONS**

Stated at ambient temperature of 23°C ± 3K (75°F ± 5), relative humidity of 50% ± 20%, atmospheric pressure, mounting position with vertical diaphragm and zero based range for transmitter with isolating diaphragms in AISI 316 L ss or Hastelloy and silicone oil fill or KTFILL-1 and HART digital trim values equal to 4-20 mA span end points, in linear mode.

Unless otherwise specified, errors are quoted as % of span. Some performance data are affected by the actual turndown (TD) as ratio between Upper Range Limit (URL) and calibrated span. IT IS RECOMMENDED TO SELECT THE TRANSMITTER SENSOR CODE PROVIDING THE TURNDOWN VALUE AS LOWEST AS POSSIBLE TO OPTIMIZE PERFORMANCE CHARACTERISTICS.

**Accuracy rating**

% of calibrated span, including combined effects of terminal based linearity, hysteresis and repeatability.

For fieldbus versions SPAN refer to analog input function block outscale range

- **Models 621ED, EE, EG**

- ± 0.075% for TD from 1:1 to 15:1  
(± 0.10% for sensor code U  
± 0.10% for sensor codes A and B for TD from 1:1 to 10:1)

- ± 0.005% x  $\frac{URL}{Span}$  for TD from 15:1 to 60:1

- (± 0.0067% x  $\frac{URL}{Span}$  for sensor code U;

- ± 0.01% x  $\frac{URL}{Span}$  for sensor codes A and B for TD from 10:1 to 20:1)

- **Models 621EH, 621EA**

- ± 0.075% for TD from 1:1 to 10:1  
(± 0.10% for sensor code U  
± 0.10% for sensor code B for TD from 1:1 to 5:1)

- ± 0.0075% x  $\frac{URL}{Span}$  for TD from 10:1 to 20:1

- (± 0.01% x  $\frac{URL}{Span}$  for sensor code U;

- ± 0.02% x  $\frac{URL}{Span}$  for sensor code B for TD from 5:1 to 10:1)

**Optional indicators accuracy**

- integral display (microprocessor driven) : no error
- analog output meter : ± 2% full scale deflection
- LCD output meter : ± 0.1% of calibrated span ± 1 unit
- CoMeter
  - digital : ± 0.10% of max span(16 mA) ± 1 digit
  - analog (bargraph) : 10%

## Operating influences

**Ambient temperature** per 20 K (36°F) change between the limits of - 20°C to + 65°C (-4 to +150°F) :

| Model     | Sensor code | for TD up to |                             |
|-----------|-------------|--------------|-----------------------------|
| 621ED, EG | C to U      | 15:1         | ± (0,05% URL + 0,08% span)  |
|           | B           | 10:1         | ± (0,075% URL + 0,12% span) |
|           | A           | 10:1         | ± (0,125% URL + 0,20% span) |
| 621EE     | N to U      | 15:1         | ± (0,08% URL + 0,13% span)  |
| 621EH, EA | C to U      | 10:1         | ± (0,10% URL + 0,16% span)  |
|           | B           | 5:1          | ± (0,15% URL + 0,24% span)  |

Multiply by 1.5 the above coefficients for 20 K (36°F) change between the limits of -40 to -20°C (-40 to -4°F) and of +65 to +85°C (+150 to 185°F)

### Optional LCD output meter ambient temperature

per 1 K (1.8°F) change between the limits of -20 and +80°C (-4 and + 176°F)

Total effect : ± (0.0002 x span units + 0.1) of reading.

### Optional CoMeter ambient temperature

Total reading error per 20K (36°F) change between the ambient limits of -20 and +70°C (-4 and +158°F) :

± 0.15% of max span (16 mA).

### Static pressure (zero errors can be calibrated out at line pressure)

per 2 MPa, 20 bar or 290 psi (range A)

per 7 MPa, 70 bar or 1015 psi (ranges B to U)

#### • Model 621ED

- zero error : ± 0.15% of URL

- span error : ± 0.15% of reading

Multiply by 1.5 the errors for sensor code B.

#### • Model 621EE

- zero error : ± 0.16% of URL

- span error : ± 0.16% of reading

per 1 MPa, 10 bar, 145 psi above atmosphere

per 0.1 MPa, 1 bar, 14.5 psi from atmosphere down to vacuum

#### • Model 621EH

- zero error : ± 0.08% of URL

- span error : ± 0.05% of reading

Multiply by 1.5 the errors for sensor code B.

### Supply voltage

Within voltage/load specified limits the total effect is less than 0.005% of URL per volt.

### Load

Within load/voltage specified limits the total effect is negligible.

### Radio frequency interference

Total effect : less than 0.10% of span from 20 to 1000 MHz and for field strengths up to 30 V/m when tested with shielded conduit and grounding, with or without meter. Meets IEC 801.

### Common mode interference

No effect from 100 V rms @ 50 Hz, or 50 Vdc.

### Series mode interference

No effect from 1 V rms @ 50 Hz.

### Mounting position

Rotations in plane of diaphragm have no effect. A tilt to 90° from vertical causes a zero shifts up to 0.5 kPa, 5 mbar or 2 inH<sub>2</sub>O, which can be corrected with the zero adjustment. No span effect.

### Stability

± 0.15% of URL over a thirty-six-month period

## PHYSICAL SPECIFICATIONS

(Refer to ordering information sheets for variant availability related to specific model or versions code)

## Materials

### Process isolating diaphragms (\*)

AISI 316 L ss, Hastelloy C276 ◊; Monel 400 ◊; Tantalum; Hastelloy C276 ◊ on AISI 316 L ss gasket seat.

### Process flanges, adapters, plugs and drain/vent valves (\*)

AISI 316 L ss; Hastelloy C ◊; Monel 400◊; Plated carbon steel with AISI 316 L ss valves

### Blind flange (reference side of 621EG, EA)

AISI 316 L ss; Plated carbon steel .

### Sensor fill fluid

Silicone oil (DC200) or inert fill (perfluorinated polyethers Galden ◊) or "process-inert" fill (KTFILL-1).

### Mounting bracket (\*\*)

Zinc plated carbon steel with chrome passivation; AISI 316 L ss

### Gaskets (\*)

Viton ◊, PTFE.

**Sensor housing** : AISI 316 L ss

### Bolts and nuts

- Plated carbon steel bolts class 8.8 per UNI 5737 (ISO 4014) and nuts class 6.S per UNI 3740/4 (ISO 898/2).
- Plated alloy steel bolts per ASTM-A-193-77a grade B7M and nuts per ASTM A194/A 194 M-90 grade 2HM, in compliance with NACE MR0175 Class II.
- AISI 316 ss bolts Class A4-80 and nuts Class A4-70 per UNI 7323 (ISO 3506).
- AISI 316 ss bolts and nuts Class A4-50 per UNI 7323 (ISO 3506), in compliance with NACE MR0175 Class II.

### Electronic housing and covers

Barrel version

- Low-copper content aluminium alloy with baked epoxy finish;
- AISI 316 L ss.

DIN version

- Low-copper content aluminium alloy with baked epoxy finish

**Covers O-ring**: Buna N.

### Local zero and span adjustments:

Glass filled polycarbonate plastic (removable)

### Tagging

AISI 316 ss data plate attached to the electronics housing.

## Calibration

- Standard: at maximum span, zero based range, ambient temperature and pressure
- Optional: at specified range and ambient conditions; or at operating temperature.

## Optional extras

### Mounting brackets

For vertical and horizontal 60 mm. (2 in) pipes or wall mounting.

### Output indicator:

plug-in rotatable type, LCD or analog.  
Standard LCD output meter scale is 0 to 100% linear; special linear scale to specified range and engineering unit is available. Standard analog output meter scale is 0 to 100% linear or 0 to 10 square-root; special graduation is available.

### Supplemental customer tag

AISI 316 ss tag screwed/fastened to the transmitter for customer's tag data up to a maximum of 20 characters and spaces on one line for tag number and tag name, and up to a maximum of 3 spaced strings of 10 characters each for calibration details (lower and upper values plus unit).  
Special typing evaluated on request for charges.

**Surge protection (not available with Profibus PA and FF output)**  
**Cleaning procedure for oxygen service; hydrogen preparation; special degreasing**  
**Material traceability; manifold**

## Environmental protection

### Wet and dust-laden atmospheres

The transmitter is dust and sand tight and protected against immersion effects as defined by IEC 529 (1989) to IP 67 (IP 68 on request) or by NEMA to 4X or by JIS to C0920

### Hazardous atmospheres

With or without output meter/integral display

#### INTRINSIC SAFETY/EUROPE:

ATEX/BASEEFA approval

- EC-Type Examination Certificate no. BAS 99ATEX 1180  
- (HART)

II 1 GD T50°C, EEx ia IIC T6/T5 (-40°C ≤ Ta ≤ +40°C)  
T95°C, EEx ia IIC T4 (-40°C ≤ Ta ≤ +85°C)

- (FOUNDATION Fieldbus)

II 1 GD T70°C, EEx ia IIC T4 (-40°C ≤ Ta ≤ +60°C)

- EC-Type Examination Certificate no. BAS 00ATEX 1241  
- (PROFIBUS-PA)

II 1 GD T70°C, EEx ia IIB T4 (-40°C ≤ Ta ≤ +60°C)

#### TYPE "N"/EUROPE :

ATEX/BASEEFA type examination

- Design compliance by Certificate no. BAS 01ATEX 3380X  
- (HART)

II 3 GD T50°C, EEx nL IIC T5 (-40°C ≤ Ta ≤ +40°C)  
T95°C, EEx nL IIC T4 (-40°C ≤ Ta ≤ +85°C)

- (FOUNDATION Fieldbus)

II 3 GD T70°C, EEx nL IIC T4 (-40°C ≤ Ta ≤ +60°C)

- Design compliance by Certificate no. BAS 01ATEX 3384X  
- (PROFIBUS-PA)

II 3 GD T70°C, EEx nL IIB T4 (-40°C ≤ Ta ≤ +60°C)

#### FLAMEPROOF/EUROPE:

ATEX/CESI approval;

- EC-Type Examination Certificate no. CESI 00 ATEX 035  
II 1/2 GD T80°C, EEx d IIC T6 (-40°C ≤ Ta ≤ +70°C)  
T95°C, EEx d IIC T5 (-40°C ≤ Ta ≤ +85°C)

#### CANADIAN STANDARDS ASSOCIATION and FACTORY MUTUAL :

- Explosionproof: Class I, Div. 1, Groups A, B, C, D
  - Dust ignitionproof : Class II, Div. 1, Groups E, F, G
  - Suitable for : Class II, Div. 2, Groups F, G; Class III, Div. 1, 2
  - Nonincendive: Class I, Div. 2, Groups A, B, C, D
  - Intrinsically safe: Class I, II, III, Div. 1, Groups A, B, C, D, E, F, G
- STANDARDS AUSTRALIA (SAA)  
TS/WCA Approval (HART only)
- Conformity Certificate no. AUS Ex 3117X  
Ex d IIC T5 (Tamb +85°C)/T6 (Tamb +70°C) Class 1 Zone 1;  
Ex ia IIC T4 (Tamb +85°C)/T5 (Tamb +55°C) T6 Class 1 Zone 0

## Process connections (according to DIN 19213)

- on flanges : 1/4 NPT on process axis
- on adapters : 1/2 NPT on process axis
- centre distance (621ED, EE, EH) : 54 mm (2.13 in ) on flange  
51,54 or 57 mm (2.01, 2.13 or 2.24 in) as per adapters fittings.

## Electrical connections

Two 1/2 NPT or M20x1.5 or PG 13.5 or 1/2 GK threaded conduit entries, direct on housing; straight or angle Harting HAN connector and one plug, on request.

### Terminal block

- HART version  
Three terminals for signal/external meter wiring up to 2.5 mm<sup>2</sup> (14 AWG) and three connection points for test and communication purposes.
- Fieldbus versions  
Two terminals for signal wiring (bus connection) up to 2.5 mm<sup>2</sup> (14 AWG)

### Grounding

Internal and external 6 mm<sup>2</sup> (10 AWG) ground termination points are provided.

## Mounting position

Transmitter can be mounted in any position.

Electronics housing may be rotated to any position. A positive stop prevents over travel.

## Mass (without options)

3.5 kg approx (8 lb); add 1.5 kg (3.4 lb) for AISI housing.  
Add 650 g (1.5 lb) for packing.

## Packing

Carton 26 x 26 x 18 cm approx (10 x 10 x 7 in).

◊ Hastelloy is a Cabot Corporation trademark

◊ Monel is an International Nickel Co. trademark

◊ Galden is a Montefluos trademark

◊ Viton is a Dupont de Nemour trademark

(\*) Wetted parts of the transmitter.

(\*\*) U-bolt material: AISI 400 ss; screws material: high-strength alloy steel or AISI 316 ss.

## CONFIGURATION

### • *Transmitter with HART communication and 4 to 20 mA*

#### Standard configuration

Transmitters are factory calibrated to customer's specified range. Calibrated range and tag number are stamped on the tag plate. If a calibration range and tag data are not specified, the transmitter will be supplied with the plate left blank and configured as follows:

- Engineering Unit: Specify code option
- 4 mA: Zero
- 20 mA: Upper Range Limit (URL)
- Output : Linear
- Damping: 1 sec.
- Transmitter failure mode: Upscale
- Software tag characters: Blank
- Optional LCD output indicator : 0 to 100.0% linear

Any or all the above configurable parameters, including Lower range-value and Upper range-value which must be the same unit of measure, can be easily changed using the HART hand-held communicator. The transmitter database is customized with specified flange type and material, O-ring and drain/vent materials and meter code option.

#### Custom configuration (option)

The following data may be specified in addition to the standard configuration parameters:

- Descriptor : 16 alphanumeric characters
- Message: 32 alphanumeric characters
- Date: Day, month, year
- Damping: Seconds

### • *Transmitter with Profibus PA communication*

Transmitters are factory calibrated to customer's specified range. Calibrated range and tag number are stamped on the tag plate. If a calibration range and tag data are not specified, the transmitter will be supplied with the plate left blank and configured as follows:

- Measure Profile: Pressure
- Engineering Unit: kPa
- Output scale 0%: Lower Range Limit (LRL)
- Output scale 100%: Upper Range Limit (URL)
- Output : Linear
- Hi-Hi Limit : Upper Range Limit (URL)
- Hi Limit : Upper Range Limit (URL)
- Low Limit : Lower Range Limit (LRL)
- Low-Low Limit : Lower Range Limit (LRL)
- Limits hysteresis: 0.5% of output scale
- PV filter: 0 sec.
- Address (settable by local key): 126
- Tag : 32 alphanumeric characters

Any or all the above configurable parameters, including Lower range-value and Upper range-value which must be the same unit of measure, can be easily changed by a PC running the configuration software Smart Vision with DTM for 600T or 600T template for Siemens Simatic PDM System. The transmitter database is customized with specified flange type and material, O-ring and drain/vent materials and meter code option.

#### Custom configuration (option)

The following data may be specified in addition to the standard configuration parameters:

- Descriptor : 32 alphanumeric characters
- Message: 32 alphanumeric characters
- Date: Day, month, year
- PV filter: Seconds

### • *Transmitter with FOUNDATION fieldbus communication*

Transmitters are factory calibrated to customer's specified range. Calibrated range and tag number are stamped on the tag plate. If a calibration range and tag data are not specified, the transmitter will be supplied with the plate left blank and configured as follows:

- Measure Profile: Pressure
- Engineering Unit: kPa
- Output scale 0%: Lower Range Limit (LRL)
- Output scale 100%: Upper Range Limit (URL)
- Output : Linear
- Hi-Hi Limit : Upper Range Limit (URL)
- Hi Limit : Upper Range Limit (URL)
- Low Limit : Lower Range Limit (LRL)
- Low-Low Limit : Lower Range Limit (LRL)
- Limits hysteresis: 0.5% of output scale
- PV filter time: 0 sec.
- Tag : 32 alphanumeric characters

Any or all the above configurable parameters, including the range values, can be changed using any host compliant to FOUNDATION fieldbus. The transmitter database is customized with specified flange type and material, O-ring and drain/vent materials and meter code option.

Available engineering units of pressure measure are :

Pa, kPa, MPa  
inH<sub>2</sub>O@4°C, mmH<sub>2</sub>O@4°C, psi  
inH<sub>2</sub>O@20°C, ftH<sub>2</sub>O@20°C, mmH<sub>2</sub>O@20°C  
inHg, mmHg, Torr  
g/cm<sup>2</sup>, kg/cm<sup>2</sup>, atm  
mbar, bar

# MOUNTING DIMENSIONS

(not for construction unless certified)

- Transmitter on bracket for vertical or horizontal 60 mm (2in) pipe mounting (Barrel housing)

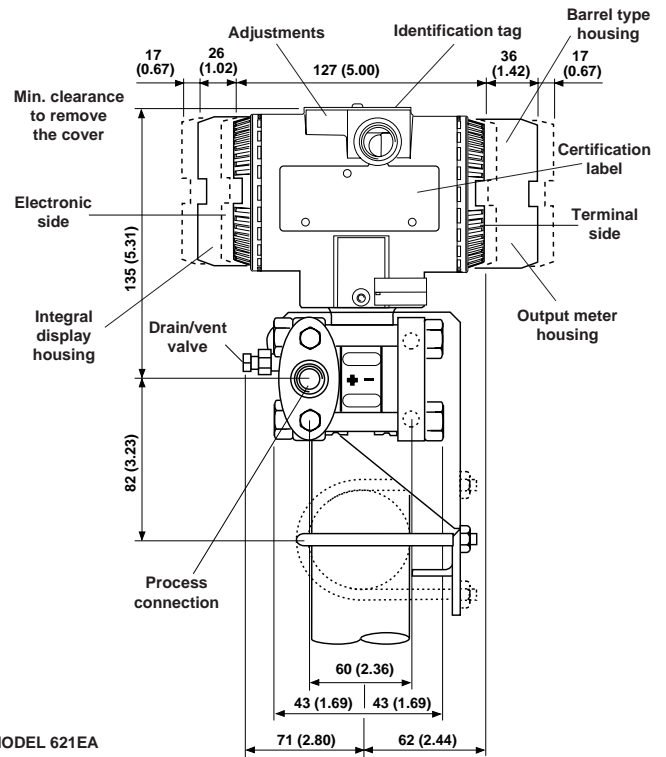
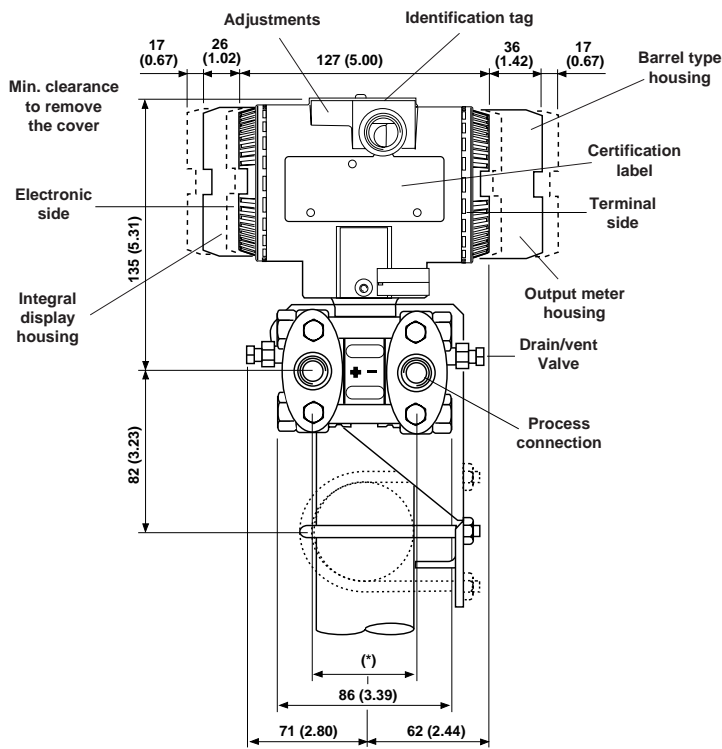

(\*) FOR MODEL 621ED, EE, EH  
 51 (2.01), 54 (2.13) or 57 (2.24) mm (in) according to 1/2"-14 NPT adapters fitting  
 54 (2.13) mm (in) on 1/4"-18 NPT process flange  
 FOR MODEL 621EG  
 54 (2.13) mm (in) with low pressure side flange without process connection and  
 drain/vent valve

NOTE : Process connection, gasket groove and gaskets are in accordance with  
 DIN 19213. Bolting threads for fixing adapter or other devices (i.e. manifold  
 etc.) on process flange is 7/16"-20 UNF.

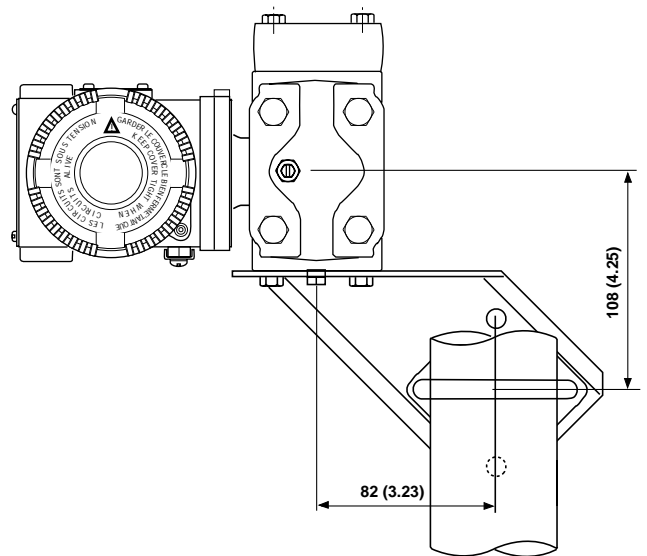
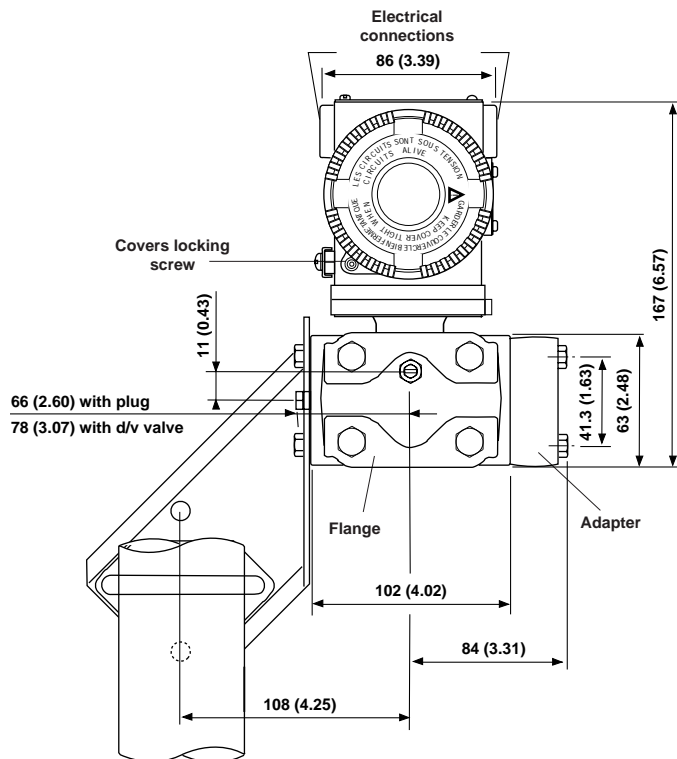

• Transmitter on bracket for vertical or horizontal 60 mm (2in) pipe mounting (DIN housing)

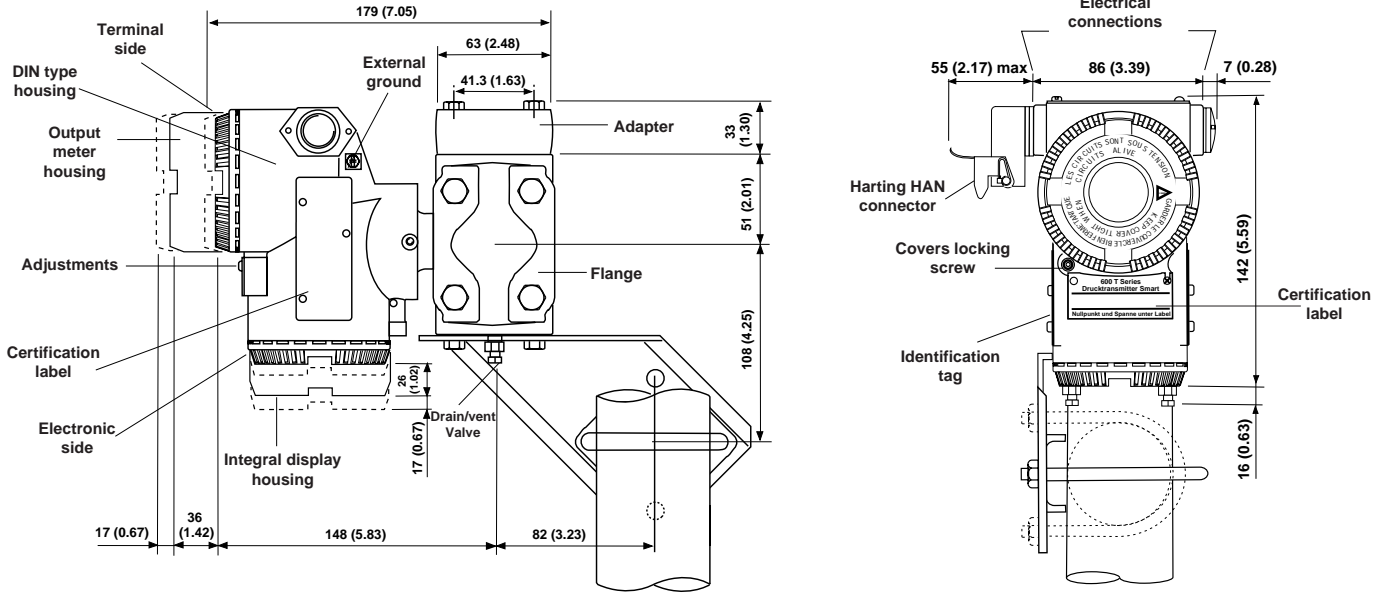

• Transmitter on bracket for wall mounting (by four M8 screws)

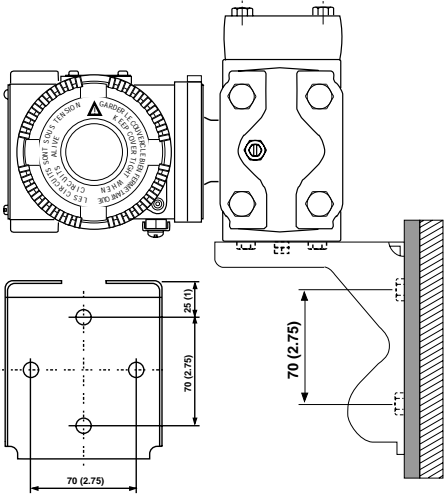

• Transmitter on flat type (for box) bracket for vertical or horizontal 60 mm (2in) pipe mounting

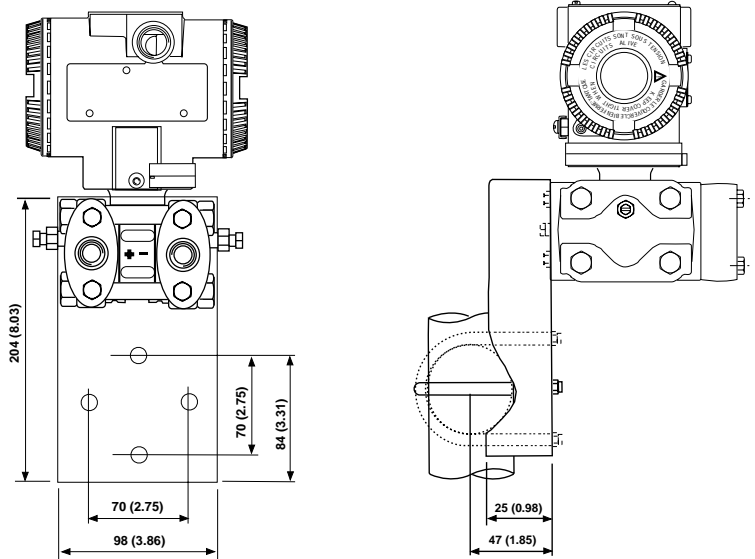

**ELECTRICAL CONNECTIONS**

• HART Version

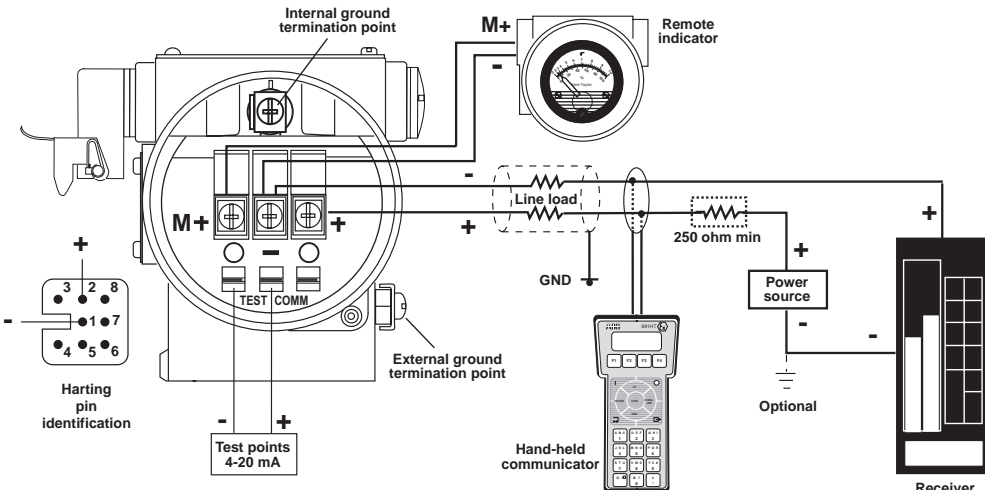

• FIELDBUS Versions

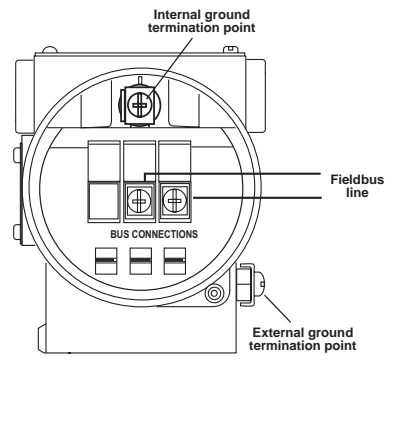

HART hand-held communicator may be connected at any wiring termination point in the loop, providing the minimum resistance is 250 ohm. If this is less than 250 ohm, additional resistance should be added to allow communications.

# ORDERING INFORMATION model 621ED Differential Pressure Transmitter (MWP=14 MPa)

Select one character or set of characters from each category and specify complete catalog number.  
Refer to supplementary code and specify another number for each transmitter if additional options are required.

## PRODUCT CODE

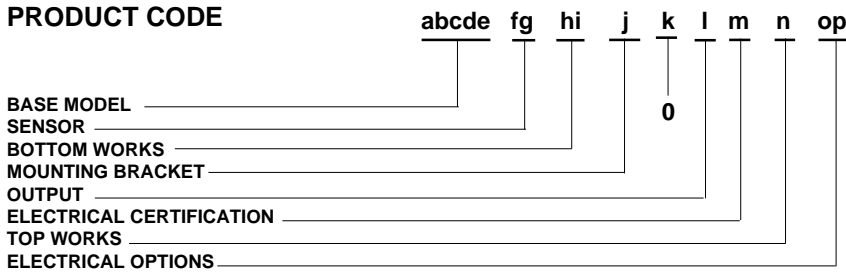

|              |   |              |
|--------------|---|--------------|
| <b>abcde</b> | <b>BASE MODEL</b> - 1st to 5th characters | <b>Code</b>  |
|              | Differential pressure transmitter         | <b>621ED</b> |

|          |                                    |                           |                           |        |
|----------|------------------------------------|---------------------------|---------------------------|--------|
| <b>f</b> | <b>SENSOR</b>                      |                           |                           |        |
|          | <b>Span limits</b> - 6th character |                           |                           |        |
|          | 0.125 and 2.5 kPa                  | 1.25 and 25 mbar          | 0.5 and 10 inH2O          | (Note) |
|          | 0.5 and 10 kPa                     | 5 and 100 mbar            | 2 and 40.1 inH2O          |        |
|          | 0.67 and 40 kPa                    | 6.7 and 400 mbar          | 2.67 and 160 inH2O        |        |
|          | 1.1 and 65 kPa                     | 11 and 650 mbar           | 4.35 and 260 inH2O        |        |
|          | <b>2.67 and 160 kPa</b>            | <b>26.7 and 1600 mbar</b> | <b>10.7 and 642 inH2O</b> |        |
|          | 10 and 600 kPa                     | 0.1 and 6 bar             | 1.45 and 87 psi           |        |
|          | 40 and 2400 kPa                    | 0.4 and 24 bar            | 5.8 and 348 psi           |        |
|          | 133 and 8000 kPa                   | 1.33 and 80 bar           | 19.3 and 1160 psi         |        |

Note : Maximum Working Pressure 8 MPa, 80 bar, 1160 psi

|          |                               |                   |        |          |
|----------|-------------------------------|-------------------|--------|----------|
| <b>g</b> | <b>7th character</b>          |                   |        |          |
|          | <b>Diaphragm material (*)</b> | <b>Fill fluid</b> |        |          |
|          | AISI 316 L ss                 | Silicone oil (**) | (Note) | <b>2</b> |
|          | Hastelloy C276 ◊ (AISI seat)  | Silicone oil (**) |        | <b>6</b> |
|          | Hastelloy C276 ◊              | Silicone oil (**) |        | <b>3</b> |
|          | Monel 400 ◊                   | Silicone oil (**) | (Note) | <b>4</b> |
|          | Tantalum                      | Silicone oil (**) | (Note) | <b>5</b> |
|          | AISI 316 L ss                 | Inert fluid       | (Note) | <b>A</b> |
|          | Hastelloy C276 ◊ (AISI seat)  | Inert fluid       | (Note) | <b>7</b> |
|          | Hastelloy C276 ◊              | Inert fluid       | (Note) | <b>B</b> |
|          | Monel 400 ◊                   | Inert fluid       | (Note) | <b>C</b> |
|          | Tantalum                      | Inert fluid       | (Note) | <b>D</b> |
|          | AISI 316 L ss                 | KTFILL-1 (**)     | (Note) | <b>L</b> |
|          | Hastelloy C276 ◊ (AISI seat)  | KTFILL-1 (**)     | (Note) | <b>P</b> |
|          | Hastelloy C276 ◊              | KTFILL-1 (**)     | (Note) | <b>N</b> |

Note : not available with sensor code A at position "f"

|          |   |  |  |          |
|----------|---|--|--|----------|
| <b>h</b> | <b>BOTTOM WORKS</b>   |  |  |          |
|          | <b>Process flanges / adapters / drain/vent valves (*)</b> - 8th character |  |  |          |
|          | <b>Material</b>   | <b>Connection</b>                                    | <b>Valves fitting</b>  |          |
|          | Plated Carbon Steel with AISI 316 L ss valves                             | 1/2" NPT-f through adapter (7/16" UNF U.S. drilling) | Valves fitted on process axis                                | <b>F</b> |
|          | AISI 316 L ss   | 1/4" NPT-f direct (7/16" UNF U.S. drilling)          |  | <b>H</b> |
|          | Hastelloy C ◊   | 1/2" NPT-f through adapter (7/16" UNF U.S. drilling) |  | <b>J</b> |
|          | Monel 400 ◊   | 1/4" NPT-f direct (7/16" UNF U.S. drilling)          |  | <b>L</b> |
|          | Plated Carbon Steel with AISI 316 L ss valves                             | 1/2" NPT-f through adapter (7/16" UNF U.S. drilling) | Valves fitted on flange side and plug fitted on process axis | <b>Q</b> |
|          | AISI 316 L ss   | 1/4" NPT-f direct (7/16" UNF U.S. drilling)          |  | <b>R</b> |
|          | Hastelloy C ◊   | 1/2" NPT-f through adapter (7/16" UNF U.S. drilling) |  | <b>T</b> |
|          | Monel 400 ◊   | 1/4" NPT-f direct (7/16" UNF U.S. drilling)          |  | <b>V</b> |
|          | Plated alloy steel  | 1/2" NPT-f through adapter (7/16" UNF U.S. drilling) |  | <b>Z</b> |
|          |   | 1/4" NPT-f direct (7/16" UNF U.S. drilling)          |  | <b>B</b> |
|          |   | 1/2" NPT-f through adapter (7/16" UNF U.S. drilling) |  | <b>1</b> |
|          |   | 1/4" NPT-f direct (7/16" UNF U.S. drilling)          |  | <b>4</b> |
|          |   | 1/2" NPT-f through adapter (7/16" UNF U.S. drilling) |  | <b>D</b> |
|          |   | 1/4" NPT-f direct (7/16" UNF U.S. drilling)          |  | <b>G</b> |
|          |   | 1/2" NPT-f through adapter (7/16" UNF U.S. drilling) |  | <b>P</b> |
|          |   | 1/4" NPT-f direct (7/16" UNF U.S. drilling)          |  | <b>S</b> |

|          |                      |                    |  |          |
|----------|----------------------|--------------------|--|----------|
| <b>i</b> | <b>9th character</b> |                    |  |          |
|          | <b>Bolts</b>         | <b>Gaskets (*)</b> |  |          |
|          | Carbon Steel         | Viton ◊ (**)       |  | <b>1</b> |
|          |                      | PTFE               |  | <b>3</b> |
|          | AISI 316 ss          | Viton ◊ (**)       |  | <b>4</b> |
|          |                      | PTFE               |  | <b>6</b> |
|          | AISI 316 ss (NACE)   | Viton ◊ (**)       |  | <b>S</b> |
|          |                      | PTFE               |  | <b>T</b> |
|          | Plated alloy steel   | Viton ◊ (**)       |  | <b>7</b> |
|          |                      | PTFE               |  | <b>A</b> |

Compliance to NACE class II bolting, according to specification MR0175, latest revision

(\*) Process wetted-parts

(\*\*) Not available for oxygen service

◊ Hastelloy is a Cabot Corporation trademark

◊ Monel is an International Nickel Co. trademark

◊ Viton is a Dupont de Nemour trademark

# ORDERING INFORMATION model 621ED Differential Pressure Transmitter (MWP=14 MPa)

## MOUNTING BRACKET - 10th character

| j | Shape  | Material                      |        |
|---|--|-------------------------------|--------|
|   | None   | None                          | 1      |
|   | For pipe mounting<br>(Not suitable for AISI housing) | Carbon steel<br>AISI 316 L ss | A<br>B |
|   | For wall mounting<br>(Not suitable for AISI housing) | Carbon steel<br>AISI 316 L ss | 5<br>6 |
|   | Flat type, for box                                   | Carbon steel<br>AISI 316 L ss | C<br>D |

| k | 11th character |   |
|---|----------------|---|
|   | Use code       | 0 |

## 12th character

| l | OUTPUT                                    |   |
|---|---|---|
|   | HART digital communication and 4 to 20 mA | G |
|   | Profibus PA communication                 | P |
|   | FOUNDATION Fieldbus Communication         | F |

| m | ELECTRICAL CERTIFICATION - 13th character  |   |
|---|--|---|
|   | General Purpose  | 1 |
|   | ATEX Group II Category 1/2 GD - Flameproof EEx d CESI approval   | F |
|   | ATEX Group II Category 1 GD - Intrinsic Safety EEx ia BASEEFA approval   | L |
|   | ATEX Group II Category 3 GD - Type of protection "N" EEx nL design compliance  | N |
|   | Factory Mutual (FM) and Canadian Standard Association (CSA) approvals (only with 1/2" NPT and M20 electrical connection) | 8 |
|   | Intrinsic Safety and Flameproof to Standards Australia SAA approval Ex ia IIC T6/T5/T4 + Ex d IIC T6/T5 (Note)           | W |

Note : not available with output code P and F at position "l"

## TOP WORKS - 14th character

| n                                   | Housing material | Electrical connection                              |   |
|-------------------------------------|------------------|--|---|
| Aluminium alloy<br>(Barrel version) |                  | 1/2" NPT   | 1 |
|                                     |                  | M20 x 1.5 (CM 20)                                  | 2 |
|                                     |                  | Pg 13.5  | 3 |
|                                     |                  | 1/2" GK  | 4 |
|                                     |                  | Harting HAN connector - straight entry (Note 1, 2) | 5 |
|                                     |                  | Harting HAN connector - angle entry (Note 1, 2)    | 6 |
| AISI 316 L ss<br>(Barrel version)   |                  | 1/2" NPT   | A |
|                                     |                  | M20 x 1.5 (CM 20)                                  | C |
|                                     |                  | Pg 13.5  | D |
|                                     |                  | 1/2" GK  | F |
| Aluminium alloy<br>(DIN version)    |                  | Pg 13.5 (Note 1)                                   | 7 |
|                                     |                  | M20 x 1.5 (CM 20) (Note 1)                         | 8 |
|                                     |                  | Harting HAN connector - straight entry (Note 1, 2) | K |

Note 1 : requires certification code 1 at position "m"

Note 2 : not available with output code P and F at position "l"

| o | ELECTRICAL OPTIONS - 15th character  |   |
|---|--|---|
|   | Internal meter type  |   |
|   | None   | 1 |
|   | Digital LCD output indicator linear 0-100%, user scalable (Note)                                     | 3 |
|   | Digital LCD output indicator linear scale (specify range and engineering units) (Note)               | 5 |
|   | Analog output indicator linear 0-100% scale (Note)   | 7 |
|   | Analog output indicator square root 0-10 scale (Note)  | 8 |
|   | Analog output indicator, special graduation (to be specified for linear or square root scale) (Note) | 9 |
|   | Digital LCD integral display   | A |
|   | Digital LCD integral display and digital LCD output indicator linear 4-20 mA (Note)                  | C |
|   | Digital LCD integral display and analog output indicator linear 0-100% scale (Note)                  | E |
|   | Programmable signal meter and HART configurator (CoMeter) (Note)                                     | P |
|   | Programmable signal meter and HART configurator (CoMeter) and digital LCD integral display (Note)    | R |

Note : not available with output code P and F at position "l"

## 16th character

| p  | Electrical options | Labels language |   |
|--|--------------------|-----------------|---|
| Standard terminal block                  |                    | English         | 1 |
|  |                    | German          | 2 |
|  |                    | Italian         | 7 |
| Surge protector (Note)                   |                    | English         | 3 |
|  |                    | German          | 4 |
|  |                    | Italian         | 8 |
| Terminal block for external meter (Note) |                    | English         | 5 |
|  |                    | German          | 6 |
|  |                    | Italian         | 9 |

Note : not available with output code P and F at position "l"

# ORDERING INFORMATION model 621EE Differential Pressure Transmitter (MWP=25 MPa)

Select one character or set of characters from each category and specify complete catalog number.

Refer to supplementary code and specify another number for each transmitter if additional options are required.

## PRODUCT CODE

abcde fg hi j k l m n op

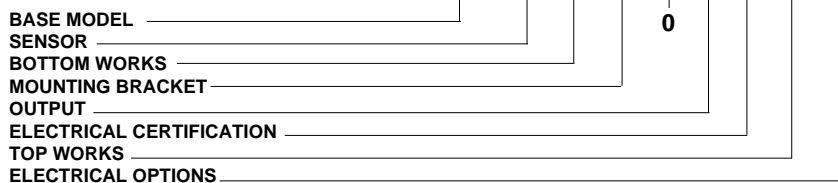

|              |   |              |
|--------------|---|--------------|
| <b>abcde</b> | <b>BASE MODEL</b> - 1st to 5th characters | <b>Code</b>  |
|              | Differential pressure transmitter         | <b>621EE</b> |

|          |                                    |                    |                    |
|----------|------------------------------------|--------------------|--------------------|
| <b>f</b> | <b>SENSOR</b>                      |                    |                    |
|          | <b>Span limits</b> - 6th character |                    |                    |
|          | 1.1 and 65 kPa                     | 11 and 650 mbar    | 4.35 and 260 inH2O |
|          | 2.67 and 160 kPa                   | 26.7 and 1600 mbar | 10.7 and 642 inH2O |
|          | 10 and 600 kPa                     | 0.1 and 6 bar      | 1.45 and 87 psi    |
|          | 40 and 2400 kPa                    | 0.4 and 24 bar     | 5.8 and 348 psi    |
|          | 133 and 8000 kPa                   | 1.33 and 80 bar    | 19.3 and 1160 psi  |
|          | 267 and 16000 kPa                  | 2.67 and 160 bar   | 38.7 and 2320 psi  |
|          |                                    |                    | <b>N</b>           |
|          |                                    |                    | <b>D</b>           |
|          |                                    |                    | <b>E</b>           |
|          |                                    |                    | <b>F</b>           |
|          |                                    |                    | <b>W</b>           |
|          |                                    |                    | <b>U</b>           |

|          |                               |                   |          |
|----------|-------------------------------|-------------------|----------|
| <b>g</b> | 7th character                 |                   |          |
|          | <b>Diaphragm material (*)</b> | <b>Fill fluid</b> |          |
|          | AISI 316 L ss                 | Silicone oil (**) | <b>2</b> |
|          | Hastelloy C276 ◊ (AISI seat)  | Silicone oil (**) | <b>6</b> |
|          | Hastelloy C276 ◊              | Silicone oil (**) | <b>3</b> |
|          | Monel 400 ◊                   | Silicone oil (**) | <b>4</b> |
|          | Tantalum                      | Silicone oil (**) | <b>5</b> |
|          | AISI 316 L ss                 | Inert fluid       | <b>A</b> |
|          | Hastelloy C276 ◊ (AISI seat)  | Inert fluid       | <b>7</b> |
|          | Hastelloy C276 ◊              | Inert fluid       | <b>B</b> |
|          | Monel 400 ◊                   | Inert fluid       | <b>C</b> |
|          | Tantalum                      | Inert fluid       | <b>D</b> |
|          | AISI 316 L ss                 | KTFILL-1 (**)     | <b>L</b> |
|          | Hastelloy C276 ◊ (AISI seat)  | KTFILL-1 (**)     | <b>P</b> |
|          | Hastelloy C276 ◊              | KTFILL-1 (**)     | <b>N</b> |

|          |   |  |                                  |   |
|----------|---|--|----------------------------------|---|
| <b>h</b> | <b>BOTTOM WORKS</b>   |  |                                  |   |
|          | <b>Process flanges / adapters / drain/vent valves (*)</b> - 8th character |  |                                  |   |
|          | <b>Material</b>   | <b>Connection</b>                                    | <b>Valves fitting</b>            |   |
|          | Plated Carbon Steel with<br>AISI 316 L ss valves                          | 1/2" NPT-f through adapter (7/16" UNF U.S. drilling) | Valves fitted on<br>process axis |   |
|          |   | 1/4" NPT-f direct (7/16" UNF U.S. drilling)          |                                  |   |
|          | AISI 316 L ss   | 1/2" NPT-f through adapter (7/16" UNF U.S. drilling) |                                  | Valves fitted on<br>flange side and<br>plug fitted on<br>process axis |
|          |   | 1/4" NPT-f direct (7/16" UNF U.S. drilling)          |                                  |   |
|          | Hastelloy C ◊   | 1/2" NPT-f through adapter (7/16" UNF U.S. drilling) |                                  |   |
|          |   | 1/4" NPT-f direct (7/16" UNF U.S. drilling)          |                                  |   |
|          | Monel 400 ◊   | 1/2" NPT-f through adapter (7/16" UNF U.S. drilling) |                                  |   |
|          |   | 1/4" NPT-f direct (7/16" UNF U.S. drilling)          |                                  |   |
|          | Plated Carbon Steel with<br>AISI 316 L ss valves                          | 1/2" NPT-f through adapter (7/16" UNF U.S. drilling) |                                  |   |
|          |   | 1/4" NPT-f direct (7/16" UNF U.S. drilling)          |                                  |   |
|          | AISI 316 L ss   | 1/2" NPT-f through adapter (7/16" UNF U.S. drilling) |                                  |   |
|          |   | 1/4" NPT-f direct (7/16" UNF U.S. drilling)          |                                  |   |
|          | Hastelloy C ◊   | 1/2" NPT-f through adapter (7/16" UNF U.S. drilling) |                                  |   |
|          |   | 1/4" NPT-f direct (7/16" UNF U.S. drilling)          |                                  |   |
|          | Monel 400 ◊   | 1/2" NPT-f through adapter (7/16" UNF U.S. drilling) |                                  |   |
|          |   | 1/4" NPT-f direct (7/16" UNF U.S. drilling)          |                                  |   |
|          |   |  | <b>F</b>                         |   |
|          |   |  | <b>H</b>                         |   |
|          |   |  | <b>J</b>                         |   |
|          |   |  | <b>L</b>                         |   |
|          |   |  | <b>Q</b>                         |   |
|          |   |  | <b>R</b>                         |   |
|          |   |  | <b>T</b>                         |   |
|          |   |  | <b>V</b>                         |   |
|          |   |  | <b>Z</b>                         |   |
|          |   |  | <b>B</b>                         |   |
|          |   |  | <b>1</b>                         |   |
|          |   |  | <b>4</b>                         |   |
|          |   |  | <b>D</b>                         |   |
|          |   |  | <b>G</b>                         |   |
|          |   |  | <b>P</b>                         |   |
|          |   |  | <b>S</b>                         |   |

|          |                    |                    |          |
|----------|--------------------|--------------------|----------|
| <b>i</b> | 9th character      |                    |          |
|          | <b>Bolts</b>       | <b>Gaskets (*)</b> |          |
|          | Carbon Steel       | Viton ◊ (**)       | <b>1</b> |
|          |                    | PTFE               | <b>3</b> |
|          | AISI 316 ss        | Viton ◊ (**)       | <b>4</b> |
|          |                    | PTFE               | <b>6</b> |
|          | Plated alloy steel | Viton ◊ (**)       | <b>7</b> |
|          |                    | PTFE               | <b>A</b> |

■ Compliance to NACE class II bolting, according to specification MR0175, latest revision

(\*) Process wetted-parts

(\*\*) Not available for oxygen service

◊ Hastelloy is a Cabot Corporation trademark

◊ Monel is an International Nickel Co. trademark

◊ Viton is a Dupont de Nemour trademark

# ORDERING INFORMATION model 621EE Differential Pressure Transmitter (MWP=25 MPa)

## MOUNTING BRACKET - 10th character

| j | Shape  | Material      |   |
|---|--|---------------|---|
|   | None   | None          | 1 |
|   | For pipe mounting<br>(Not suitable for AISI housing) | Carbon steel  | A |
|   |  | AISI 316 L ss | B |
|   | For wall mounting<br>(Not suitable for AISI housing) | Carbon steel  | 5 |
|   |  | AISI 316 L ss | 6 |
|   | Flat type, for box                                   | Carbon steel  | C |
|   |  | AISI 316 L ss | D |

| k | 11th character |   |
|---|----------------|---|
|   | Use code       | 0 |

12th character

| l | OUTPUT                                    |   |
|---|---|---|
|   | HART digital communication and 4 to 20 mA | G |
|   | Profibus PA communication                 | P |
|   | FOUNDATION Fieldbus Communication         | F |

| m | ELECTRICAL CERTIFICATION - 13th character  |   |
|---|--|---|
|   | General Purpose  | 1 |
|   | ATEX Group II Category 1/2 GD - Flameproof EEx d CESI approval   | F |
|   | ATEX Group II Category 1 GD - Intrinsic Safety EEx ia BASEEFA approval   | L |
|   | ATEX Group II Category 3 GD - Type of protection "N" EEx nL design compliance  | N |
|   | Factory Mutual (FM) and Canadian Standard Association (CSA) approvals (only with 1/2" NPT and M20 electrical connection) | 8 |
|   | Intrinsic Safety and Flameproof to Standards Australia SAA approval Ex ia IIC T6/T5/T4 + Ex d IIC T6/T5 (Note)           | W |

Note : not available with output code P and F at position "l"

## TOP WORKS - 14th character

| n                                   | Housing material | Electrical connection                              |   |
|-------------------------------------|------------------|--|---|
| Aluminium alloy<br>(Barrel version) |                  | 1/2" NPT   | 1 |
|                                     |                  | M20 x 1.5 (CM 20)                                  | 2 |
|                                     |                  | Pg 13.5  | 3 |
|                                     |                  | 1/2" GK  | 4 |
|                                     |                  | Harting HAN connector - straight entry (Note 1, 2) | 5 |
|                                     |                  | Harting HAN connector - angle entry (Note 1, 2)    | 6 |
| AISI 316 L ss<br>(Barrel version)   |                  | 1/2" NPT   | A |
|                                     |                  | M20 x 1.5 (CM 20)                                  | C |
|                                     |                  | Pg 13.5  | D |
|                                     |                  | 1/2" GK  | F |
| Aluminium alloy<br>(DIN version)    |                  | Pg 13.5 (Note 1)                                   | 7 |
|                                     |                  | M20 x 1.5 (CM 20) (Note 1)                         | 8 |
|                                     |                  | Harting HAN connector - straight entry (Note 1, 2) | K |

Note 1 : requires certification code 1 at position "m"

Note 2 : not available with output code P and F at position "l"

## ELECTRICAL OPTIONS - 15th character

| o | Internal meter type  |   |
|---|--|---|
|   | None   | 1 |
|   | Digital LCD output indicator linear 0-100%, user scalable (Note)                                     | 3 |
|   | Digital LCD output indicator linear scale (specify range and engineering units) (Note)               | 5 |
|   | Analog output indicator linear 0-100% scale (Note)   | 7 |
|   | Analog output indicator square root 0-10 scale (Note)  | 8 |
|   | Analog output indicator, special graduation (to be specified for linear or square root scale) (Note) | 9 |
|   | Digital LCD integral display   | A |
|   | Digital LCD integral display and digital LCD output indicator linear 4-20 mA (Note)                  | C |
|   | Digital LCD integral display and analog output indicator linear 0-100% scale (Note)                  | E |
|   | Programmable signal meter and HART configurator (CoMeter) (Note)                                     | P |
|   | Programmable signal meter and HART configurator (CoMeter) and digital LCD integral display (Note)    | R |

Note : not available with output code P and F at position "l"

16th character

| p  | Electrical options | Labels language |   |
|--|--------------------|-----------------|---|
| Standard terminal block                  |                    | English         | 1 |
|  |                    | German          | 2 |
|  |                    | Italian         | 7 |
| Surge protector (Note)                   |                    | English         | 3 |
|  |                    | German          | 4 |
|  |                    | Italian         | 8 |
| Terminal block for external meter (Note) |                    | English         | 5 |
|  |                    | German          | 6 |
|  |                    | Italian         | 9 |

Note : not available with output code P and F at position "l"

# ORDERING INFORMATION model 621EH Differential Pressure Transmitter (high vacuum)

Select one character or set of characters from each category and specify complete catalog number.

Refer to supplementary code and specify another number for each transmitter if additional options are required.

## PRODUCT CODE

abcde fg hi j k l m n op

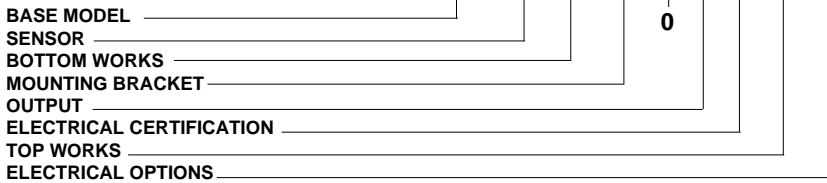

|              |   |              |
|--------------|---|--------------|
| <b>abcde</b> | <b>BASE MODEL</b> - 1st to 5th characters | <b>Code</b>  |
|              | Differential pressure transmitter         | <b>621EH</b> |

|          |                                    |                   |                  |
|----------|------------------------------------|-------------------|------------------|
| <b>f</b> | <b>SENSOR</b>                      |                   |                  |
|          | <b>Span limits</b> - 6th character |                   |                  |
|          | 1 and 10 kPa                       | 10 and 100 mbar   | 4 and 40.1 inH2O |
|          | 2 and 40 kPa                       | 20 and 400 mbar   | 8 and 160 inH2O  |
|          | 3.25 and 65 kPa                    | 32.5 and 650 mbar | 13 and 260 inH2O |
|          | 8 and 160 kPa                      | 80 and 1600 mbar  | 32 and 642 inH2O |

|          |                               |                    |          |
|----------|-------------------------------|--------------------|----------|
| <b>g</b> | <b>7th character</b>          |                    |          |
|          | <b>Diaphragm material (*)</b> | <b>Fill fluid</b>  |          |
|          | AISI 316 L ss                 | Silicone oil (**)  | <b>2</b> |
|          | Hastelloy C276 ◊ (AISI seat)  | Silicone oil (**)  | <b>6</b> |
|          | Hastelloy C276 ◊              | Silicone oil (**)  | <b>3</b> |
|          | AISI 316 L ss                 | Inert fluid (Note) | <b>A</b> |
|          | Hastelloy C276 ◊ (AISI seat)  | Inert fluid (Note) | <b>7</b> |
|          | Hastelloy C276 ◊              | Inert fluid (Note) | <b>B</b> |
|          | AISI 316 L ss                 | KTFILL-1 (**)      | <b>L</b> |
|          | Hastelloy C276 ◊ (AISI seat)  | KTFILL-1 (**)      | <b>P</b> |
|          | Hastelloy C276 ◊              | KTFILL-1 (**)      | <b>N</b> |

Note : not available with sensor code B at position "f"

|          |   |  |                                  |   |
|----------|---|--|----------------------------------|---|
| <b>h</b> | <b>BOTTOM WORKS</b>   |  |                                  |   |
|          | <b>Process flanges / adapters / drain/vent valves (*)</b> - 8th character |  |                                  |   |
|          | <b>Material</b>   | <b>Connection</b>                                    | <b>Valves fitting</b>            |   |
|          | Plated Carbon Steel with<br>AISI 316 L ss valves                          | 1/2" NPT-f through adapter (7/16" UNF U.S. drilling) | Valves fitted on<br>process axis |   |
|          |   | 1/4" NPT-f direct (7/16" UNF U.S. drilling)          |                                  |   |
|          | AISI 316 L ss   | 1/2" NPT-f through adapter (7/16" UNF U.S. drilling) |                                  |   |
|          |   | 1/4" NPT-f direct (7/16" UNF U.S. drilling)          |                                  |   |
|          | Hastelloy C ◊   | 1/2" NPT-f through adapter (7/16" UNF U.S. drilling) |                                  |   |
|          |   | 1/4" NPT-f direct (7/16" UNF U.S. drilling)          |                                  |   |
|          | Monel 400 ◊   | 1/2" NPT-f through adapter (7/16" UNF U.S. drilling) |                                  |   |
|          |   | 1/4" NPT-f direct (7/16" UNF U.S. drilling)          |                                  |   |
|          | Plated Carbon Steel with<br>AISI 316 L ss valves                          | 1/2" NPT-f through adapter (7/16" UNF U.S. drilling) |                                  | Valves fitted on<br>flange side and<br>plug fitted on<br>process axis |
|          |   | 1/4" NPT-f direct (7/16" UNF U.S. drilling)          |                                  |   |
|          | AISI 316 L ss   | 1/2" NPT-f through adapter (7/16" UNF U.S. drilling) |                                  |   |
|          |   | 1/4" NPT-f direct (7/16" UNF U.S. drilling)          |                                  |   |
|          | Hastelloy C ◊   | 1/2" NPT-f through adapter (7/16" UNF U.S. drilling) |                                  |   |
|          |   | 1/4" NPT-f direct (7/16" UNF U.S. drilling)          |                                  |   |
|          | Monel 400 ◊   | 1/2" NPT-f through adapter (7/16" UNF U.S. drilling) |                                  |   |
|          |   | 1/4" NPT-f direct (7/16" UNF U.S. drilling)          |                                  |   |

|          |                      |                    |          |
|----------|----------------------|--------------------|----------|
| <b>i</b> | <b>9th character</b> |                    |          |
|          | <b>Bolts</b>         | <b>Gaskets (*)</b> |          |
|          | Carbon Steel         | Viton ◊ (**)       | <b>1</b> |
|          |                      | PTFE               | <b>3</b> |
|          | AISI 316 ss          | Viton ◊ (**)       | <b>4</b> |
|          |                      | PTFE               | <b>6</b> |
|          | AISI 316 ss (NACE)   | Viton ◊ (**)       | <b>S</b> |
|          |                      | PTFE               | <b>T</b> |
|          | Plated alloy steel   | Viton ◊ (**)       | <b>7</b> |
|          |                      | PTFE               | <b>A</b> |

|          |  |                 |
|----------|--|-----------------|
| <b>j</b> | <b>MOUNTING BRACKET</b> - 10th character             |                 |
|          | <b>Shape</b>   | <b>Material</b> |
|          | None   | None            |
|          | For pipe mounting<br>(Not suitable for AISI housing) | Carbon steel    |
|          |  | AISI 316 L ss   |
|          | For wall mounting<br>(Not suitable for AISI housing) | Carbon steel    |
|          |  | AISI 316 L ss   |
|          | Flat type, for box                                   | Carbon steel    |
|          |  | AISI 316 L ss   |

Compliance to NACE class II bolting, according to specification MR0175, latest revision

(\*) Process wetted-parts

(\*\*) Not available for oxygen service

◊ Hastelloy is a Cabot Corporation trademark

◊ Monel is an International Nickel Co. trademark

◊ Viton is a Dupont de Nemour trademark

# ORDERING INFORMATION model 621EH Differential Pressure Transmitter (high vacuum)

|          |                |  |          |
|----------|----------------|--|----------|
| <b>k</b> | 11th character |  |          |
|          | Use code       |  | <b>0</b> |

12th character

|          |   |  |          |
|----------|---|--|----------|
| <b>i</b> | <b>OUTPUT</b>                             |  |          |
|          | HART digital communication and 4 to 20 mA |  | <b>G</b> |
|          | Profibus PA communication                 |  | <b>P</b> |
|          | FOUNDATION Fieldbus Communication         |  | <b>F</b> |

|          |  |  |          |
|----------|--|--|----------|
| <b>m</b> | <b>ELECTRICAL CERTIFICATION - 13th character</b>   |  |          |
|          | General Purpose  |  | <b>1</b> |
|          | ATEX Group II Category 1/2 GD - Flameproof EEx d CESA approval   |  | <b>F</b> |
|          | ATEX Group II Category 1 GD - Intrinsic Safety EEx ia BASEEFA approval   |  | <b>L</b> |
|          | ATEX Group II Category 3 GD - Type of protection "N" EEx nL design compliance  |  | <b>N</b> |
|          | Factory Mutual (FM) and Canadian Standard Association (CSA) approvals (only with 1/2" NPT and M20 electrical connection) |  | <b>8</b> |
|          | Intrinsic Safety and Flameproof to Standards Australia SAA approval Ex ia IIC T6/T5/T4 + Ex d IIC T6/T5 (Note)           |  | <b>W</b> |

Note : not available with output code P and F at position "i"

**TOP WORKS - 14th character**

|          |                                     |  |          |
|----------|-------------------------------------|--|----------|
| <b>n</b> | <b>Housing material</b>             | <b>Electrical connection</b>                       |          |
|          | Aluminium alloy<br>(Barrel version) | 1/2" NPT   | <b>1</b> |
|          |                                     | M20 x 1.5 (CM 20)                                  | <b>2</b> |
|          |                                     | Pg 13.5  | <b>3</b> |
|          |                                     | 1/2" GK  | <b>4</b> |
|          |                                     | Harting HAN connector - straight entry (Note 1, 2) | <b>5</b> |
|          |                                     | Harting HAN connector - angle entry (Note 1, 2)    | <b>6</b> |
|          | AISI 316 L ss<br>(Barrel version)   | 1/2" NPT   | <b>A</b> |
|          |                                     | M20 x 1.5 (CM 20)                                  | <b>C</b> |
|          |                                     | Pg 13.5  | <b>D</b> |
|          |                                     | 1/2" GK  | <b>F</b> |
|          | Aluminium alloy<br>(DIN version)    | Pg 13.5 (Note 1)                                   | <b>7</b> |
|          |                                     | M20 x 1.5 (CM 20) (Note 1)                         | <b>8</b> |
|          |                                     | Harting HAN connector - straight entry (Note 1, 2) | <b>K</b> |

Note 1 : requires certification code 1 at position "m"

Note 2 : not available with output code P and F at position "i"

**ELECTRICAL OPTIONS - 15th character**

|          |  |  |          |
|----------|--|--|----------|
| <b>o</b> | <b>Internal meter type</b>   |  |          |
|          | None   |  | <b>1</b> |
|          | Digital LCD output indicator linear 0-100%, user scalable (Note)                                     |  | <b>3</b> |
|          | Digital LCD output indicator linear scale (specify range and engineering units) (Note)               |  | <b>5</b> |
|          | Analog output indicator linear 0-100% scale (Note)   |  | <b>7</b> |
|          | Analog output indicator square root 0-10 scale (Note)  |  | <b>8</b> |
|          | Analog output indicator, special graduation (to be specified for linear or square root scale) (Note) |  | <b>9</b> |
|          | Digital LCD integral display   |  | <b>A</b> |
|          | Digital LCD integral display and digital LCD output indicator linear 4-20 mA (Note)                  |  | <b>C</b> |
|          | Digital LCD integral display and analog output indicator linear 0-100% scale (Note)                  |  | <b>E</b> |
|          | Programmable signal meter and HART configurator (CoMeter) (Note)                                     |  | <b>P</b> |
|          | Programmable signal meter and HART configurator (CoMeter) and digital LCD integral display (Note)    |  | <b>R</b> |

Note : not available with output code P and F at position "i"

16th character

|          |  |                        |          |
|----------|--|------------------------|----------|
| <b>p</b> | <b>Electrical options</b>                | <b>Labels language</b> |          |
|          | Standard terminal block                  | English                | <b>1</b> |
|          |  | German                 | <b>2</b> |
|          |  | Italian                | <b>7</b> |
|          | Surge protector (Note)                   | English                | <b>3</b> |
|          |  | German                 | <b>4</b> |
|          |  | Italian                | <b>8</b> |
|          | Terminal block for external meter (Note) | English                | <b>5</b> |
|          |  | German                 | <b>6</b> |
|          |  | Italian                | <b>9</b> |

Note : not available with output code P and F at position "i"

# ORDERING INFORMATION model 621EG Gauge Pressure Transmitter

Select one character or set of characters from each category and specify complete catalog number.  
Refer to supplementary code and specify another number for each transmitter if additional options are required.

## PRODUCT CODE

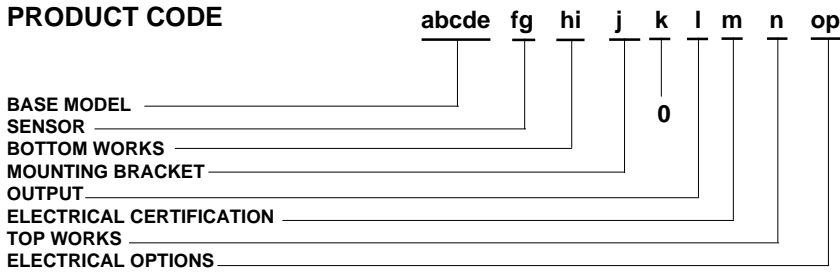

|              |   |              |
|--------------|---|--------------|
| <b>abcde</b> | <b>BASE MODEL</b> - 1st to 5th characters | <b>Code</b>  |
|              | Gauge pressure transmitter                | <b>621EG</b> |

|          |               |                                    |                           |
|----------|---------------|------------------------------------|---------------------------|
| <b>f</b> | <b>SENSOR</b> | <b>Span limits</b> - 6th character |                           |
|          |               | 0.5 and 10 kPa                     | 5 and 100 mbar            |
|          |               | 0.67 and 40 kPa                    | 6.7 and 400 mbar          |
|          |               | 1.1 and 65 kPa                     | 11 and 650 mbar           |
|          |               | 2.67 and 160 kPa                   | 26.7 and 1600 mbar        |
|          |               | 10 and 600 kPa                     | 0.1 and 6 bar             |
|          |               | 40 and 2400 kPa                    | 0.4 and 24 bar            |
|          |               | 133 and 8000 kPa                   | 1.33 and 80 bar           |
|          |               | 267 and 16000 kPa                  | 2.67 and 160 bar          |
|          |               |                                    | 2 and 40.1 inH2O (Note)   |
|          |               |                                    | 2.67 and 160 inH2O (Note) |
|          |               |                                    | 4.35 and 260 inH2O (Note) |
|          |               |                                    | 10.7 and 642 inH2O (Note) |
|          |               |                                    | 1.45 and 87 psi (Note)    |
|          |               |                                    | 5.8 and 348 psi (Note)    |
|          |               |                                    | 19.3 and 1160 psi (Note)  |
|          |               |                                    | 38.7 and 2320 psi         |

Note : Maximum Working Pressure 14 MPa, 140 bar, 2030 psi

|          |                               |                   |          |
|----------|-------------------------------|-------------------|----------|
| <b>g</b> | <b>Diaphragm material (*)</b> | <b>Fill fluid</b> |          |
|          | AISI 316 L ss                 | Silicone oil (**) | <b>2</b> |
|          | Hastelloy C276 ◊ (AISI seat)  | Silicone oil (**) | <b>6</b> |
|          | Hastelloy C276 ◊              | Silicone oil (**) | <b>3</b> |
|          | Monel 400 ◊                   | Silicone oil (**) | <b>4</b> |
|          | Tantalum                      | Silicone oil (**) | <b>5</b> |
|          | AISI 316 L ss                 | Inert fluid       | <b>A</b> |
|          | Hastelloy C276 ◊ (AISI seat)  | Inert fluid       | <b>7</b> |
|          | Hastelloy C276 ◊              | Inert fluid       | <b>B</b> |
|          | Monel 400 ◊                   | Inert fluid       | <b>C</b> |
|          | Tantalum                      | Inert fluid       | <b>D</b> |
|          | AISI 316 L ss                 | KTFILL-1 (**)     | <b>L</b> |
|          | Hastelloy C276 ◊ (AISI seat)  | KTFILL-1 (**)     | <b>P</b> |
|          | Hastelloy C276 ◊              | KTFILL-1 (**)     | <b>N</b> |

|          |  |   |   |
|----------|--|---|---|
| <b>h</b> | <b>BOTTOM WORKS</b>                              | <b>Process flanges / adapters / drain/vent valves (*)</b> - 8th character |   |
|          | <b>Material</b>                                  | <b>Connection</b>   | <b>Valves fitting</b>   |
|          | Plated Carbon Steel with<br>AISI 316 L ss valves | 1/2" NPT-f through adapter (7/16" UNF U.S. drilling)                      | Valves fitted on<br>process axis                                      |
|          |  | 1/4" NPT-f direct (7/16" UNF U.S. drilling)                               |   |
|          |  | 1/4" NPT-f direct for manifold block (7/16" UNF U.S. drilling)            |   |
|          | AISI 316 L ss                                    | 1/2" NPT-f through adapter (7/16" UNF U.S. drilling)                      |   |
|          |  | 1/4" NPT-f direct (7/16" UNF U.S. drilling)                               |   |
|          |  | 1/4" NPT-f direct for manifold block (7/16" UNF U.S. drilling)            |   |
|          | Hastelloy C ◊                                    | 1/2" NPT-f through adapter (7/16" UNF U.S. drilling)                      |   |
|          |  | 1/4" NPT-f direct (7/16" UNF U.S. drilling)                               |   |
|          |  | 1/4" NPT-f direct for manifold block (7/16" UNF U.S. drilling)            |   |
|          | Monel 400 ◊                                      | 1/2" NPT-f through adapter (7/16" UNF U.S. drilling)                      |   |
|          |  | 1/4" NPT-f direct (7/16" UNF U.S. drilling)                               |   |
|          |  | 1/4" NPT-f direct for manifold block (7/16" UNF U.S. drilling)            |   |
|          | Plated Carbon Steel with<br>AISI 316 L ss valves | 1/2" NPT-f through adapter (7/16" UNF U.S. drilling)                      | Valves fitted on<br>flange side and<br>plug fitted on<br>process axis |
|          |  | 1/4" NPT-f direct (7/16" UNF U.S. drilling)                               |   |
|          | AISI 316 L ss                                    | 1/2" NPT-f through adapter (7/16" UNF U.S. drilling)                      |   |
|          |  | 1/4" NPT-f direct (7/16" UNF U.S. drilling)                               |   |
|          | Hastelloy C ◊                                    | 1/2" NPT-f through adapter (7/16" UNF U.S. drilling)                      |   |
|          |  | 1/4" NPT-f direct (7/16" UNF U.S. drilling)                               |   |
|          | Monel 400 ◊                                      | 1/2" NPT-f through adapter (7/16" UNF U.S. drilling)                      |   |
|          |  | 1/4" NPT-f direct (7/16" UNF U.S. drilling)                               |   |

|          |                                      |              |                    |
|----------|--------------------------------------|--------------|--------------------|
| <b>i</b> | <b>9th character</b>                 | <b>Bolts</b> | <b>Gaskets (*)</b> |
|          | Carbon Steel                         | Viton ◊ (**) | <b>1</b>           |
|          |                                      | PTFE         | <b>3</b>           |
|          | AISI 316 ss                          | Viton ◊ (**) | <b>4</b>           |
|          |                                      | PTFE         | <b>6</b>           |
|          | AISI 316 ss (NACE)<br>(MWP = 16 MPa) | Viton ◊ (**) | <b>S</b>           |
|          |                                      | PTFE         | <b>T</b>           |
|          | Plated alloy steel                   | Viton ◊ (**) | <b>7</b>           |
|          |                                      | PTFE         | <b>A</b>           |

Compliance to NACE class II bolting, according to specification MR0175, latest revision  
 (\*) Process wetted-parts  
 (\*\*) Not available for oxygen service

◊ Hastelloy is a Cabot Corporation trademark  
 ◊ Monel is an International Nickel Co. trademark  
 ◊ Viton is a Dupont de Nemour trademark

# ORDERING INFORMATION model 621EG Gauge Pressure Transmitter

## MOUNTING BRACKET - 10th character

| j | Shape  | Material      |   |
|---|--|---------------|---|
|   | None   | None          | 1 |
|   | For pipe mounting<br>(Not suitable for AISI housing) | Carbon steel  | A |
|   |  | AISI 316 L ss | B |
|   | For wall mounting<br>(Not suitable for AISI housing) | Carbon steel  | 5 |
|   |  | AISI 316 L ss | 6 |
|   | Flat type, for box                                   | Carbon steel  | C |
|   |  | AISI 316 L ss | D |

| k | 11th character |   |
|---|----------------|---|
|   | Use code       | 0 |

## 12th character

| l | OUTPUT                                    |   |
|---|---|---|
|   | HART digital communication and 4 to 20 mA | G |
|   | Profibus PA communication                 | P |
|   | FOUNDATION Fieldbus Communication         | F |

| m | ELECTRICAL CERTIFICATION - 13th character  |   |
|---|--|---|
|   | General Purpose  | 1 |
|   | ATEX Group II Category 1/2 GD - Flameproof EEx d CESI approval   | F |
|   | ATEX Group II Category 1 GD - Intrinsic Safety EEx ia BASEEFA approval   | L |
|   | ATEX Group II Category 3 GD - Type of protection "N" EEx nL design compliance  | N |
|   | Factory Mutual (FM) and Canadian Standard Association (CSA) approvals (only with 1/2" NPT and M20 electrical connection) | 8 |
|   | Intrinsic Safety and Flameproof to Standards Australia SAA approval Ex ia IIC T6/T5/T4 + Ex d IIC T6/T5 (Note)           | W |

Note : not available with output code P and F at position "l"

## TOP WORKS - 14th character

| n                                   | Housing material | Electrical connection                              |   |
|-------------------------------------|------------------|--|---|
| Aluminium alloy<br>(Barrel version) |                  | 1/2" NPT   | 1 |
|                                     |                  | M20 x 1.5 (CM 20)                                  | 2 |
|                                     |                  | Pg 13.5  | 3 |
|                                     |                  | 1/2" GK  | 4 |
|                                     |                  | Harting HAN connector - straight entry (Note 1, 2) | 5 |
|                                     |                  | Harting HAN connector - angle entry (Note 1, 2)    | 6 |
| AISI 316 L ss<br>(Barrel version)   |                  | 1/2" NPT   | A |
|                                     |                  | M20 x 1.5 (CM 20)                                  | C |
|                                     |                  | Pg 13.5  | D |
|                                     |                  | 1/2" GK  | F |
| Aluminium alloy<br>(DIN version)    |                  | Pg 13.5 (Note 1)                                   | 7 |
|                                     |                  | M20 x 1.5 (CM 20) (Note 1)                         | 8 |
|                                     |                  | Harting HAN connector - straight entry (Note 1, 2) | K |

Note 1 : requires certification code 1 at position "m"

Note 2 : not available with output code P and F at position "l"

## ELECTRICAL OPTIONS - 15th character

| o | Internal meter type   |   |
|---|---|---|
|   | None  | 1 |
|   | Digital LCD output indicator linear 0-100%, user scalable (Note)                                  | 3 |
|   | Digital LCD output indicator linear scale (specify range and engineering units) (Note)            | 5 |
|   | Analog output indicator linear 0-100% scale (Note)  | 7 |
|   | Analog output indicator, special graduation (to be specified for linear scale) (Note)             | 9 |
|   | Digital LCD integral display  | A |
|   | Digital LCD integral display and digital LCD output indicator linear 4-20 mA (Note)               | C |
|   | Digital LCD integral display and analog output indicator linear 0-100% scale (Note)               | E |
|   | Programmable signal meter and HART configurator (CoMeter) (Note)                                  | P |
|   | Programmable signal meter and HART configurator (CoMeter) and digital LCD integral display (Note) | R |

Note : not available with output code P and F at position "l"

## 16th character

| p  | Electrical options | Labels language |   |
|--|--------------------|-----------------|---|
| Standard terminal block                  |                    | English         | 1 |
|  |                    | German          | 2 |
|  |                    | Italian         | 7 |
| Surge protector (Note)                   |                    | English         | 3 |
|  |                    | German          | 4 |
|  |                    | Italian         | 8 |
| Terminal block for external meter (Note) |                    | English         | 5 |
|  |                    | German          | 6 |
|  |                    | Italian         | 9 |

Note : not available with output code P and F at position "l"

# ORDERING INFORMATION model 621EA Absolute Pressure Transmitter

Select one character or set of characters from each category and specify complete catalog number.  
Refer to supplementary code and specify another number for each transmitter if additional options are required.

## PRODUCT CODE

abcde fg hi j k l m n op

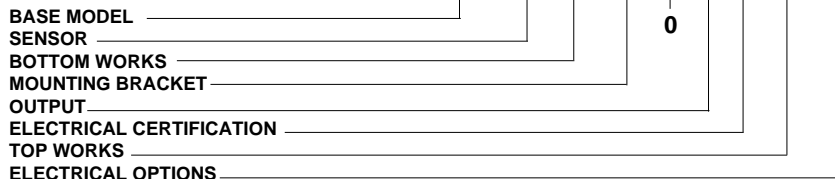

|       |                                    |       |
|-------|------------------------------------|-------|
| abcde | BASE MODEL - 1st to 5th characters | Code  |
|       | Absolute pressure transmitter      | 621EA |

| SENSOR |                             |                   |                  |        |   |
|--------|-----------------------------|-------------------|------------------|--------|---|
| f      | Span limits - 6th character |                   |                  |        |   |
|        | 1 and 10 kPa                | 10 and 100 mbar   | 7.5 and 75 mmHg  | (Note) | B |
|        | 2 and 40 kPa                | 20 and 400 mbar   | 15 and 300 mmHg  | (Note) | C |
|        | 3.25 and 65 kPa             | 32.5 and 650 mbar | 24 and 480 mmHg  | (Note) | N |
|        | 8 and 160 kPa               | 80 and 1600 mbar  | 60 and 1200 mmHg | (Note) | D |
|        | 30 and 600 kPa              | 0.3 and 6 bar     | 4.35 and 87 psi  | (Note) | E |
|        | 120 and 2400 kPa            | 1.2 and 24 bar    | 17.4 and 348 psi | (Note) | F |
|        | 400 and 8000 kPa            | 4 and 80 bar      | 58 and 1160 psi  | (Note) | W |
|        | 800 and 16000 kPa           | 8 and 160 bar     | 116 and 2320 psi |        | U |

Note : Maximum Working Pressure 14 MPa, 140 bar, 2030 psi

| 7th character |                              |                    |        |   |
|---------------|------------------------------|--------------------|--------|---|
| g             | Diaphragm material (*)       | Fill fluid         |        |   |
|               | AISI 316 L ss                | Silicone oil (**)  |        | 2 |
|               | Hastelloy C276 ◊ (AISI seat) | Silicone oil (**)  |        | 6 |
|               | Hastelloy C276 ◊             | Silicone oil (**)  |        | 3 |
|               | AISI 316 L ss                | Inert fluid (Note) |        | A |
|               | Hastelloy C276 ◊ (AISI seat) | Inert fluid (Note) |        | 7 |
|               | Hastelloy C276 ◊             | Inert fluid (Note) |        | B |
|               | AISI 316 L ss                | KTFILL-1 (**)      | (Note) | L |
|               | Hastelloy C276 ◊ (AISI seat) | KTFILL-1 (**)      | (Note) | P |
|               | Hastelloy C276 ◊             | KTFILL-1 (**)      | (Note) | N |

Note : not available with sensor code B at position "f"

| BOTTOM WORKS   |  |  |  |   |
|--|--|--|--|---|
| Process flanges / adapters / drain/vent valves (*) - 8th character |  |  |  |   |
| h  | Material   | Connection   | Valves fitting   |   |
|  | Plated Carbon Steel with AISI 316 L ss valves                  | 1/2" NPT-f through adapter (7/16" UNF U.S. drilling)           | Valves fitted on process axis                                | F |
|  |  | 1/4" NPT-f direct (7/16" UNF U.S. drilling)                    |  | H |
|  |  | 1/4" NPT-f direct for manifold block (7/16" UNF U.S. drilling) |  | E |
|  | AISI 316 L ss  | 1/2" NPT-f through adapter (7/16" UNF U.S. drilling)           |  | J |
|  |  | 1/4" NPT-f direct (7/16" UNF U.S. drilling)                    |  | L |
|  |  | 1/4" NPT-f direct for manifold block (7/16" UNF U.S. drilling) |  | 6 |
| Hastelloy C ◊  | 1/2" NPT-f through adapter (7/16" UNF U.S. drilling)           | Q  |  |   |
|  | 1/4" NPT-f direct (7/16" UNF U.S. drilling)                    | R  |  |   |
|  | 1/4" NPT-f direct for manifold block (7/16" UNF U.S. drilling) | Y  |  |   |
| Monel 400 ◊  | 1/2" NPT-f through adapter (7/16" UNF U.S. drilling)           | T  |  |   |
|  | 1/4" NPT-f direct (7/16" UNF U.S. drilling)                    | V  |  |   |
|  | 1/4" NPT-f direct for manifold block (7/16" UNF U.S. drilling) | C  |  |   |
|  | Plated Carbon Steel with AISI 316 L ss valves                  | 1/2" NPT-f through adapter (7/16" UNF U.S. drilling)           | Valves fitted on flange side and plug fitted on process axis | Z |
|  |  | 1/4" NPT-f direct (7/16" UNF U.S. drilling)                    |  | B |
|  |  | 1/2" NPT-f through adapter (7/16" UNF U.S. drilling)           |  | 1 |
|  | AISI 316 L ss  | 1/4" NPT-f direct (7/16" UNF U.S. drilling)                    |  | 4 |
|  |  | 1/2" NPT-f through adapter (7/16" UNF U.S. drilling)           |  | D |
|  |  | 1/4" NPT-f direct (7/16" UNF U.S. drilling)                    |  | G |
| Hastelloy C ◊  | 1/2" NPT-f through adapter (7/16" UNF U.S. drilling)           | P  |  |   |
|  | 1/4" NPT-f direct (7/16" UNF U.S. drilling)                    | S  |  |   |
| Monel 400 ◊  | 1/2" NPT-f through adapter (7/16" UNF U.S. drilling)           |  |  |   |
|  | 1/4" NPT-f direct (7/16" UNF U.S. drilling)                    |  |  |   |

| 9th character |                                      |              |  |   |
|---------------|--------------------------------------|--------------|--|---|
| i             | Bolts                                | Gaskets (*)  |  |   |
|               | Carbon Steel                         | Viton ◊ (**) |  | 1 |
|               |                                      | PTFE         |  | 3 |
|               | AISI 316 ss                          | Viton ◊ (**) |  | 4 |
|               |                                      | PTFE         |  | 6 |
|               | AISI 316 ss (NACE)<br>(MWP = 16 MPa) | Viton ◊ (**) |  | S |
|               |                                      | PTFE         |  | T |
|               |                                      | Viton ◊ (**) |  | 7 |
|               | Plated alloy steel                   | PTFE         |  | A |

■ Compliance to NACE class II bolting, according to specification MR0175, latest revision

(\*) Process wetted-parts

(\*\*) Not available for oxygen service

◊ Hastelloy is a Cabot Corporation trademark

◊ Monel is an International Nickel Co. trademark

◊ Viton is a Dupont de Nemour trademark

# ORDERING INFORMATION model 621EA Absolute Pressure Transmitter

## MOUNTING BRACKET - 10th character

| j | Shape  | Material      |   |
|---|--|---------------|---|
|   | None   | None          | 1 |
|   | For pipe mounting<br>(Not suitable for AISI housing) | Carbon steel  | A |
|   |  | AISI 316 L ss | B |
|   | For wall mounting<br>(Not suitable for AISI housing) | Carbon steel  | 5 |
|   |  | AISI 316 L ss | 6 |
|   | Flat type, for box                                   | Carbon steel  | C |
|   |  | AISI 316 L ss | D |

| k | 11th character |   |
|---|----------------|---|
|   | Use code       | 0 |

## 12th character

| l | OUTPUT                                    |   |
|---|---|---|
|   | HART digital communication and 4 to 20 mA | G |
|   | Profibus PA communication                 | P |
|   | FOUNDATION Fieldbus Communication         | F |

| m | ELECTRICAL CERTIFICATION - 13th character  |   |
|---|--|---|
|   | General Purpose  | 1 |
|   | ATEX Group II Category 1/2 GD - Flameproof EEx d CESI approval   | F |
|   | ATEX Group II Category 1 GD - Intrinsic Safety EEx ia BASEEFA approval   | L |
|   | ATEX Group II Category 3 GD - Type of protection "N" EEx nL design compliance  | N |
|   | Factory Mutual (FM) and Canadian Standard Association (CSA) approvals (only with 1/2" NPT and M20 electrical connection) | 8 |
|   | Intrinsic Safety and Flameproof to Standards Australia SAA approval Ex ia IIC T6/T5/T4 + Ex d IIC T6/T5 (Note)           | W |

Note : not available with output code P and F at position "l"

## TOP WORKS - 14th character

| n                                   | Housing material | Electrical connection                              |   |
|-------------------------------------|------------------|--|---|
| Aluminium alloy<br>(Barrel version) |                  | 1/2" NPT   | 1 |
|                                     |                  | M20 x 1.5 (CM 20)                                  | 2 |
|                                     |                  | Pg 13.5  | 3 |
|                                     |                  | 1/2" GK  | 4 |
|                                     |                  | Harting HAN connector - straight entry (Note 1, 2) | 5 |
|                                     |                  | Harting HAN connector - angle entry (Note 1, 2)    | 6 |
| AISI 316 L ss<br>(Barrel version)   |                  | 1/2" NPT   | A |
|                                     |                  | M20 x 1.5 (CM 20)                                  | C |
|                                     |                  | Pg 13.5  | D |
|                                     |                  | 1/2" GK  | F |
| Aluminium alloy<br>(DIN version)    |                  | Pg 13.5 (Note 1)                                   | 7 |
|                                     |                  | M20 x 1.5 (CM 20) (Note 1)                         | 8 |
|                                     |                  | Harting HAN connector - straight entry (Note 1, 2) | K |

Note 1 : requires certification code 1 at position "m"

Note 2 : not available with output code P and F at position "l"

## ELECTRICAL OPTIONS - 15th character

| o | Internal meter type   |   |
|---|---|---|
|   | None  | 1 |
|   | Digital LCD output indicator linear 0-100%, user scalable (Note)                                  | 3 |
|   | Digital LCD output indicator linear scale (specify range and engineering units) (Note)            | 5 |
|   | Analog output indicator linear 0-100% scale (Note)  | 7 |
|   | Analog output indicator, special graduation (to be specified for linear scale) (Note)             | 9 |
|   | Digital LCD integral display  | A |
|   | Digital LCD integral display and digital LCD output indicator linear 4-20 mA (Note)               | C |
|   | Digital LCD integral display and analog output indicator linear 0-100% scale (Note)               | E |
|   | Programmable signal meter and HART configurator (CoMeter) (Note)                                  | P |
|   | Programmable signal meter and HART configurator (CoMeter) and digital LCD integral display (Note) | R |

Note : not available with output code P and F at position "l"

## 16th character

| p  | Electrical options | Labels language |   |
|--|--------------------|-----------------|---|
| Standrad terminal block                  |                    | English         | 1 |
|  |                    | German          | 2 |
|  |                    | Italian         | 7 |
| Surge protector (Note)                   |                    | English         | 3 |
|  |                    | German          | 4 |
|  |                    | Italian         | 8 |
| Terminal block for external meter (Note) |                    | English         | 5 |
|  |                    | German          | 6 |
|  |                    | Italian         | 9 |

Note : not available with output code P and F at position "l"

# ORDERING INFORMATION

Select one character or set of characters from each category and specify complete catalog number in addition to each transmitter code, if required.

## PRODUCT CODE

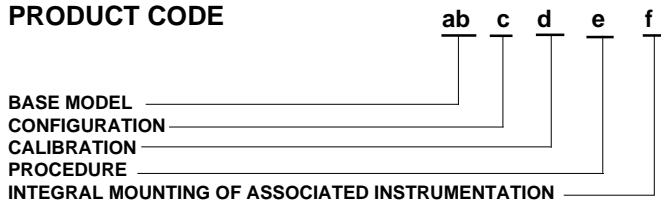

|           |   |             |
|-----------|---|-------------|
| <b>ab</b> | <b>BASE MODEL</b> - 1st to 2nd characters | <b>Code</b> |
|           | Supplementary code                        | <b>SC</b>   |

|          |  |          |
|----------|--|----------|
| <b>c</b> | <b>CONFIGURATION</b> - 3rd character                           |          |
|          | Standard - Pressure = kPa; Temperature = deg. C                | <b>1</b> |
|          | Standard - Pressure = inH2O/psi (@ 20°C); Temperature = deg. F | <b>2</b> |
|          | Standard - Pressure = inH2O/psi (@ 4°C); Temperature = deg. F  | <b>3</b> |
|          | Standard - Pressure = inH2O/psi (@ 20°C); Temperature = deg. C | <b>4</b> |
|          | Standard - Pressure = inH2O/psi (@ 4°C); Temperature = deg. C  | <b>5</b> |
|          | Custom   | <b>C</b> |

|          |                                    |                       |                |          |
|----------|------------------------------------|-----------------------|----------------|----------|
| <b>d</b> | <b>CALIBRATION</b> - 4th character |                       |                |          |
|          | <b>Calibration range</b>           | <b>Calibration</b>    |                |          |
|          | Standard (max span = 0 to URL)     | Reference temperature | None           | <b>1</b> |
|          |                                    |                       | Yes (3 copies) | <b>2</b> |
|          |                                    | Operating temperature | None           | <b>3</b> |
|          |                                    |                       | Yes (3 copies) | <b>4</b> |
|          | At specified range                 | Reference temperature | None           | <b>5</b> |
|          |                                    |                       | Yes (3 copies) | <b>6</b> |
|          |                                    | Operating temperature | None           | <b>7</b> |
|          |                                    |                       | Yes (3 copies) | <b>8</b> |

|          |                                  |   |          |
|----------|----------------------------------|---|----------|
| <b>e</b> | <b>PROCEDURE</b> - 5th character | <b>Material traceability</b>  |          |
|          | None                             | None  | <b>0</b> |
|          |                                  | To EN10204 - 3.1.B (certificates for flanges, adapters, diaphragms) | <b>A</b> |
|          |                                  | To EN10204 - 2.1 (declaration for instrument)                       | <b>B</b> |
|          | Oxygen service cleaning          | None  | <b>2</b> |
|          |                                  | To EN10204 - 3.1.B (certificates for flanges, adapters, diaphragms) | <b>C</b> |
|          |                                  | To EN10204 - 2.1 (declaration for instrument)                       | <b>F</b> |
|          | Hydrogen service preparation     | None  | <b>3</b> |
|          |                                  | To EN10204 - 3.1.B (certificates for flanges, adapters, diaphragms) | <b>D</b> |
|          |                                  | To EN10204 - 2.1 (declaration for instrument)                       | <b>H</b> |
|          | Special degreasing               | None  | <b>4</b> |
|          |                                  | To EN10204 - 3.1.B (certificates for flanges, adapters, diaphragms) | <b>E</b> |
|          |                                  | To EN10204 - 2.1 (declaration for instrument)                       | <b>K</b> |

|          |  |          |
|----------|--|----------|
| <b>f</b> | <b>INTEGRAL MOUNTING OF ASSOCIATED INSTRUMENTATION</b> - 6th character                         |          |
|          | None   | <b>0</b> |
|          | For valve manifold   | <b>1</b> |
|          | For integral orifice (only available for differential pressure transmitter)                    | <b>2</b> |
|          | For valve manifold and integral orifice (only available for differential pressure transmitter) | <b>3</b> |



The Company's policy is one of continuous product improvement and the right is reserved to modify the specifications contained herein without notice.

**ABB Instrumentation spa**  
Via Statale 113  
22016 Lenno (Como)  
Italia  
Tel. 0344 58111  
Facsimile 0344 56278

**ABB Ltd.**  
Howard Road  
St. Neots, Cambs.  
England PE19 3EU  
Tel. (01480) 475321,  
Facsimile (01480) 217948

**ABB Inc.**  
125 East County Line Road  
Warminster, Pa.  
18974-4995 USA  
Tel. (215) 674-6693/6320/6777  
Facsimile (215) 674-7184