

SGC40 and SGS40
Sight Glasses

Installation and Maintenance Instructions

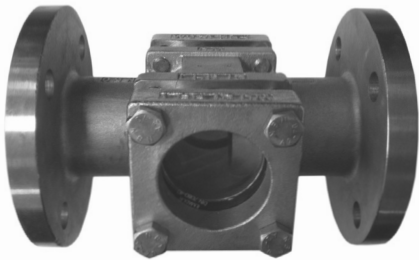

1. Safety information
2. General product information
3. Installation
4. Commissioning
5. Operation
6. Maintenance
7. Spare parts

1. Safety information

Safe operation of these products can only be guaranteed if they are properly installed, commissioned, used and maintained by qualified personnel (see Section 1.11) in compliance with the operating instructions. General installation and safety instructions for pipeline and plant construction, as well as the proper use of tools and safety equipment must also be complied with.

Warning

The gaskets used in these units contain thin stainless steel support rings which may cause physical injury if not handled and disposed of carefully.

Under certain conditions corrosive elements in the flow media can affect the inside face of the window, particularly where caustic alkali and hydrofluoric acid are present. Mica glass protectors must be used to protect the glass when the unit is used on steam applications or when the pH is higher than pH9 or when the temperature is above 150 °C with a pH greater than pH7 (see Section 2.1).

Regular inspection of the glass to check for thinning of the window must be undertaken based on an assessment of your system. If there is evidence of thinning or erosion damage, then the window should be replaced immediately. Always wear eye protection when viewing the contents of the sight glass.

Reasonable steps should be taken to protect personnel from injury in the unlikely event that the window breaks.

Safety note - Handling precautions

PTFE

Within its working temperature range PTFE is a completely inert material, but when heated to its sintering temperature it gives rise to gaseous decomposition products or fumes which can produce unpleasant effects if inhaled. The inhalation of these fumes is easily prevented by applying local exhaust ventilation to atmosphere as near to their source as possible.

Smoking should be prohibited in workshops where PTFE is handled because tobacco contaminated with PTFE will during burning give rise to polymer fumes. It is therefore important to avoid contamination of clothing, especially the pockets, with PTFE and to maintain a reasonable standard of personal cleanliness by washing hands and removing any PTFE particles lodged under the fingernails.

1.1 Intended use

Referring to the Installation and Maintenance Instructions, nameplate and Technical Information Sheet, check that the products are suitable for the intended use / application.

The products listed below comply with the requirements of the European Pressure Equipment Directive 2014/68/EU and carry the  with the Notifying Body number when so required.

The products fall within the following Pressure Equipment Directive categories:

Product		Group 2 Gases	Group 2 Liquid
DN15	-	SEP	SEP
DN20	-	SEP	SEP
DN25	-	SEP	SEP
DN32	All except CL150-JIS10	SEP	SEP
	CL150 and JIS10	SEP	SEP
DN40	All except CL150-JIS10	1	SEP
	CL150 and JIS10	SEP	SEP
DN50	All except CL150-JIS10	1	SEP
	CL150 and JIS10	SEP	SEP
DN65	All except CL150-JIS10	1	SEP
	CL150	1	SEP
	JIS10	SEP	SEP
DN80	All except CL150-JIS10	1	SEP
	CL150 and JIS10	1	SEP
DN100	All except CL150-JIS10	1	SEP
	CL150 and JIS10	1	SEP

- i) These products have been specifically designed for use on steam, compressed air, water and other industrial fluids that are in Group 2 of the above-mentioned European Pressure Equipment Directive 2014/68/EU.
- ii) Check material suitability, pressure and temperature and their maximum and minimum values. If the maximum operating limits of the product are lower than those of the system in which it is being fitted, or if malfunction of the product could result in a dangerous overpressure or overtemperature occurrence, ensure a safety device is included in the system to prevent such over-limit situations.
- iii) Determine the correct installation situation and direction of fluid flow.
- iv) Spirax Sarco products are not intended to withstand external stresses that may be induced by any system to which they are fitted. It is the responsibility of the installer to consider these stresses and take adequate precautions to minimise them.
- v) Remove protection covers from all connections and protective film from all name-plates, where appropriate, before installation on steam or other high temperature applications.
- vi) Prior to use, the user shall ensure the fluid compatibility with the equipment material.

1.2 Access

Ensure safe access and if necessary a safe working platform (suitably guarded) before attempting to work on the product. Arrange suitable lifting gear if required.

1.3 Lighting

Ensure adequate lighting, particularly where detailed or intricate work is required.

1.4 Hazardous liquids or gases in the pipeline

Consider what is in the pipeline or what may have been in the pipeline at some previous time. Consider: flammable materials, substances hazardous to health, extremes of temperature.

1.5 Hazardous environment around the product

Consider: explosion risk areas, lack of oxygen (e.g. tanks, pits), dangerous gases, extremes of temperature, hot surfaces, fire hazard (e.g. during welding), excessive noise, moving machinery.

1.6 Isolation

Consider the effect on the complete system of the work proposed. Will any proposed action (e.g. closing isolation valves, electrical isolation) put any other part of the system or any personnel at risk?

Dangers might include isolation of vents or protective devices or the rendering ineffective of controls or alarms. Ensure isolation valves are turned on and off in a gradual way to avoid system shocks.

1.7 Pressure

Before attempting any maintenance consider what is or may have been in the pipeline. Ensure that any pressure is isolated and safely vented to atmospheric pressure before attempting to maintain the product, this is easily achieved by fitting Spirax Sarco depressurisation valves type DV (see separate literature for details) and consider double isolation (double block and bleed) and the locking or labelling of closed valves. Do not assume that the system is depressurised even when a pressure gauge indicates zero.

1.8 Temperature

Allow time for temperature to normalise after isolation to avoid the danger of burns and consider whether protective clothing (including safety glasses) is required.

PTFE seals

If seals made from PTFE have been subjected to a temperature approaching 260 °C (500 °F) or higher, they will give off toxic fumes, which if inhaled are likely to cause temporary discomfort. It is essential for a no smoking rule to be enforced in all areas where PTFE is stored, handled or processed as persons inhaling the fumes from burning tobacco contaminated with PTFE particles can develop 'polymer fume fever'.

1.9 Tools and consumables

Before starting work ensure that you have suitable tools and/or consumables available. Use only genuine Spirax Sarco replacement parts.

1.10 Protective clothing

Consider whether you and/or others in the vicinity require any protective clothing to protect against the hazards of, for example, chemicals, high/low temperature, radiation, noise, falling objects, and dangers to eyes and face.

1.11 Permits to work

All work must be carried out or be supervised by a suitably competent person.

Installation and operating personnel should be trained in the correct use of the product according to the Installation and Maintenance Instructions.

Where a formal 'permit to work' system is in force it must be complied with. Where there is no such system, it is recommended that a responsible person should know what work is going on and, where necessary, arrange to have an assistant whose primary responsibility is safety.

Post 'warning notices' if necessary.

1.12 Handling

Manual handling of large and/or heavy products may present a risk of injury. Lifting, pushing, pulling, carrying or supporting a load by bodily force can cause injury particularly to the back. You are advised to assess the risks taking into account the task, the individual, the load and the working environment and use the appropriate handling method depending on the circumstances of the work being done.

1.13 Residual hazards

In normal use the external surface of the product may be very hot. If used at the maximum permitted operating conditions the surface temperature of some products may reach temperatures of 280 °C (536 °F).

Many products are not self-draining. Take due care when dismantling or removing the product from an installation (refer to 'Maintenance instructions').

1.14 Freezing

Provision must be made to protect products which are not self-draining against frost damage in environments where they may be exposed to temperatures below freezing point.

1.15 Disposal

Unless otherwise stated in the Installation and Maintenance Instructions, these products are recyclable and no ecological hazard is anticipated with their disposal providing due care is taken.

However, if the sight gill is fitted with a PTFE seal, special care must be taken to avoid potential health hazards associated with decomposition/burning of these seals.

Please visit the Spirax Sarco product compliance web pages

<https://www.spiraxsarco.com/product-compliance>,

for up to date information on any substances of concern that may be contained within this product. Where no additional information is provided on the Spirax Sarco product compliance web page, this product may be safely recycled and/or disposed providing due care is taken. Always check your local recycling and disposal regulations.

PTFE:

- Can only be disposed of by approved methods, not incineration.
- Keep PTFE waste in a separate container, do not mix it with other rubbish, and consign it to a landfill site.

1.16 Returning products

Customers and stockists are reminded that under EC Health, Safety and Environment Law, when returning products to Spirax Sarco they must provide information on any hazards and the precautions to be taken due to contamination residues or mechanical damage which may present a health, safety or environmental risk. This information must be provided in writing including Health and Safety data sheets relating to any substances identified as hazardous or potentially hazardous.

2. General product information

2.1 General description

The SGC40 cast carbon steel and SGS40 stainless steel are double window sight glasses having screwed, sanitary clamp, socket weld and flanged connections.

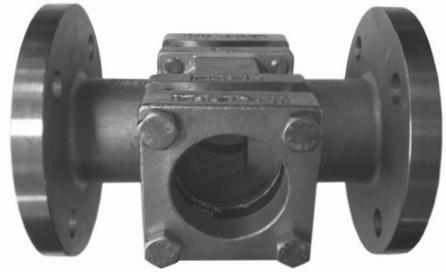



Fig. 1

Standards

These products fully comply with the requirements of the European Pressure Equipment Directive 2014/68/EU and carry the  marks when so required.

Certification

These products are available with a manufacturer's Typical Test Report and if specified certification to EN 10204 3.1.

Note: All certification/inspection requirements must be stated at the time of order placement.

Optional extras:

- Visual flow indicator flap to check the flow of the liquid in the pipeline.
- Spring: The visual flow indicator flap can be spring loaded for applications on vertical lines or where there is high flow rates.
- Mica glass protectors for severe applications - when these have been specified the nomenclature becomes SGC40M and SGS40M.
- Glass filled PTFE gasket.

Please see table below to identify when Mica glass protectors are to be used.

Application	Glass choice to be used
Steam or > pH9	Mica glass protectors and Borosilicate glass windows
>150 °C and > pH7	Mica glass protectors and Borosilicate glass windows
<150 °C and < pH7	Borosilicate glass windows only

Note: For further information see the following Technical Information Sheet TI-P130-28.

2.2 Sizes and pipe connections

½", ¾", 1", 1¼", 1½" and 2" Screwed BSP T Rp (ISO 7-1), NPT and Socket weld.

DN15, DN20, DN25, DN40 and DN50 Sanitary clamp connections to ASME BPE.

DN15, DN20, DN25, DN32, DN40, DN50, DN65, DN80 and DN100.

Flanged EN 1092 PN40, ASME Class 150 and Class 300, JIS/KS 10 and JIS/KS 20.

Flanged versions have face-to-face dimensions in accordance with EN 558 Series 1.

2.3 Pressure/temperature limits

SGC40 Carbon steel

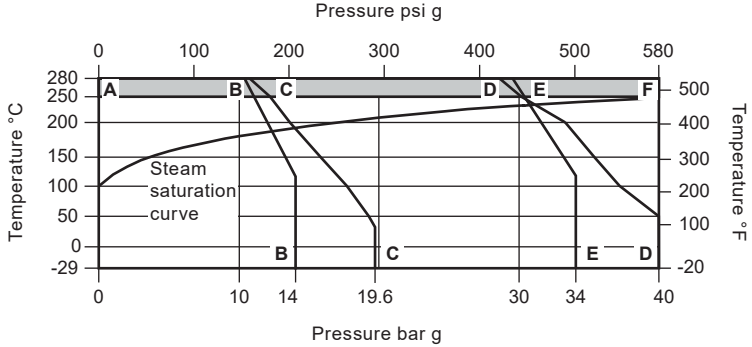

SGS40 Stainless steel

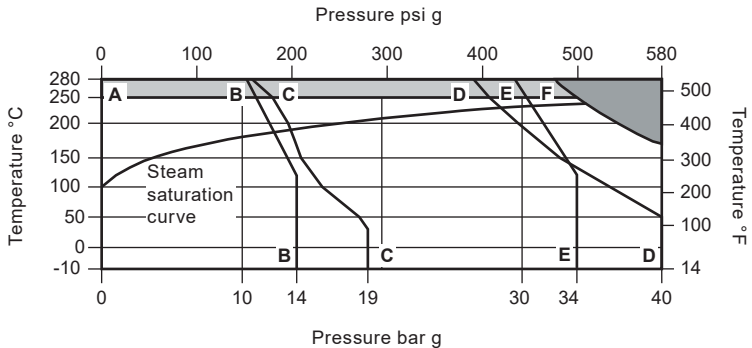

 Only graphite gasket to be used on this region.

 The product **must not** be used in this region.

A-B-B Flanged JIS 10 and KS 10.

A-C-C Flanged ASME 150.

A-D-D Flanged EN 1092 PN40.

A-E-E Flanged JIS 20 and KS 20.

A-F-D Screwed BSP T Rp (ISO 7-1), NPT, Sanitary clamp, Socket weld and Flanged ASME 300.

Body design conditions		PN40		
PMA	Maximum allowable pressure	SGC40 and SGS40	PN40	40 bar g @ 50 °C
			With PTFE gasket	250 °C
TMA	Maximum allowable temperature	SGC40 and SGS40	With graphite gasket	280 °C
			PN40	31.1 bar g @ 238 °C
PMO	Maximum allowable pressure for saturated steam service	SGC40	ASME 150	13.8 bar g @ 198 °C
			ASME 300	40 bar g @ 252 °C
			JIS/KS10	12.5 bar g @ 195 °C
			JIS/KS20	30.3 bar g @ 236 °C
		SGS40	PN40	28.3 bar g @ 232 °C
			ASME 150	12.9 bar g @ 195 °C
			ASME 300	32.8 bar g @ 241 °C
			JIS/KS10	12.5 bar g @ 195 °C
		JIS/KS20	30.3 bar g @ 236 °C	
TMO	Maximum operating temperature	SGC40 and SGS40	With PTFE gasket	250 °C
			With graphite gasket	280 °C
Minimum operating temperature		SGC40	-29 °C	
		SGS40	-10 °C	
Note: For lower operating temperatures consult Spirax Sarco				
Product is safe for use under full vacuum conditions				
Designed for a maximum cold hydraulic test pressure of:			60 bar g	

2.4 Dimensions/weights (approximate) in mm and kg

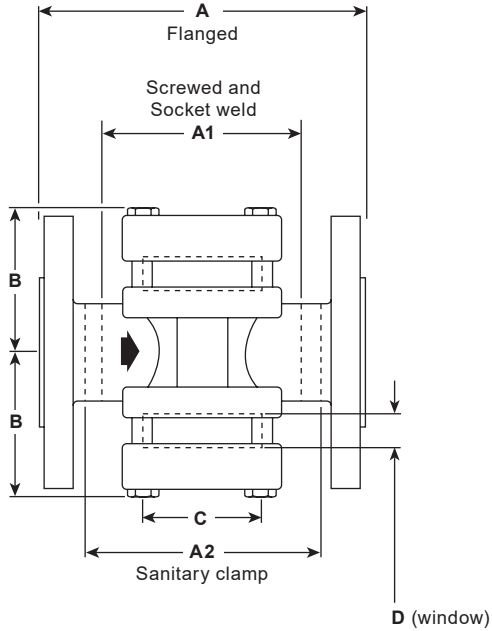

Size	Dimensions (mm)						Weight (kg)		
	A	A1	A2	B	C	D	Flanged	Screwed Socket weld	Sanitary clamp
DN15	130	95	120	48.5	46.7	10	3.5	2	2
DN20	150	95	140	51	46.7	10	4.3	2	2.2
DN25	160	95	155	68.5	60.8	15	6.4	3.5	4
DN32	-	150	-	91.5	71.4	15	-	7	-
DN32 flanged	180	-	-	72	60.8	15	7.8	-	-
DN40	-	150	202	91.5	71.4	20	-	6.75	7.4
DN40 flanged	200	-	-	86.5	71.4	20	10.5	-	-
DN50	230	150	232	91.5	71.4	20	12.5	6	7.6
DN65	290	-	-	126.5	113.2	30	27.7	-	-
DN80	310	-	-	134	113.2	30	31	-	-
DN100	350	-	-	143	113.2	30	37	-	-

2.5 Product name-plates

As standard the name-plates are stamped SGC40 and SGS40.

When the unit has been supplied or modified with Mica glass protectors its nomenclature becomes SGC40M and SGS40M - Consequently the name-plate will be stamped accordingly.

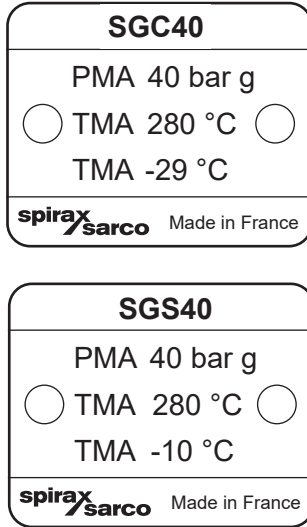

Fig. 2 Standard name-plates

3. Installation

Notes:

1. Before actioning any installation observe the 'Safety information' in Section 1.
2. Apply the appropriate grease to SGS40 stainless steel screwed units to avoid cold welding.

Warning

The gaskets used in these units contain thin stainless steel support rings which may cause physical injury if not handled and disposed of carefully.

Under certain conditions corrosive elements in the flow media can affect the inside face of the window, particularly where caustic alkali and hydrofluoric acid are present. Mica glass protectors must be used to protect the glass when the unit is used on steam applications or when the ph is higher than ph9 or when the temperature is above 150 °C with a ph greater than ph7 (see Section 2.1).

Regular inspection of the glass to check for thinning of the window must be undertaken based on an assessment of your system. If there is evidence of thinning or erosion damage, then the window should be replaced immediately. Always wear eye protection when viewing the contents of the sight glass.

Reasonable steps should be taken to protect personnel from injury in the unlikely event that the window breaks.

Applications that incorporate sight glasses should have stop valves fitted on both the inlet and outlet. It is imperative that the upstream stop valve is closed first in order to prevent over pressurisation.

Sight glasses must be fitted on the outlet side of a steam trap in either a horizontal or vertical pipeline in accordance with the flow arrow on the body.

Warning: when the optional visual flow indicator flap is requested for horizontal flow applications the hinge must be placed uppermost otherwise it will not work for the purpose intended - See Figure 3. Where the trap is a blast discharge type e.g. thermodynamic, the sight glass must be fitted at least 1 m (3 ft) from the trap. This is to ensure that the glass is not subjected to thermal shock or pressure. Ensure access is available for maintenance purposes.

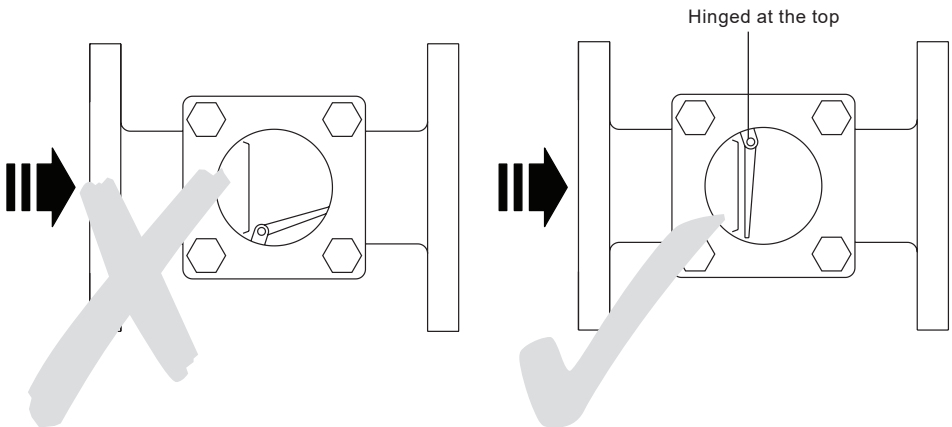

Fig. 3

4. Commissioning

After installation or maintenance ensure that the system is fully functional. Carry out tests on any alarms or protective devices.

5. Operation

The sight glass promotes turbulence in the sight glass when the fluid is passing through it. The turbulent flow inside the sight glass permits any fluid to be detected.

Sight glasses can be used to detect blocked valves, strainers, steam traps and other pipeline equipment. Sight glasses can also be used for inspection purposes, i.e. to compare the colour of the fluid at different stages of the process, enabling adjustments to be made quickly and effectively.

6. Maintenance

6.1 Maintenance

Note: Before actioning any maintenance programme observe the 'Safety information' in Section 1.

How to renew the windows, gaskets and visual flow indicator or Mica protection:

- Isolate the sight glass and allow the pressure and temperature to reduce to ambient conditions.
- After isolation unscrew the cover bolts (5) and remove the old gaskets (4) and windows (3).
- Carefully clean the recess.
- Refit new gaskets and windows, ensuring that a gasket (4) is fitted to either side of each window (3). If Mica protection is changed fit the Mica protection between the glass and the gasket as shown in Fig. 4.

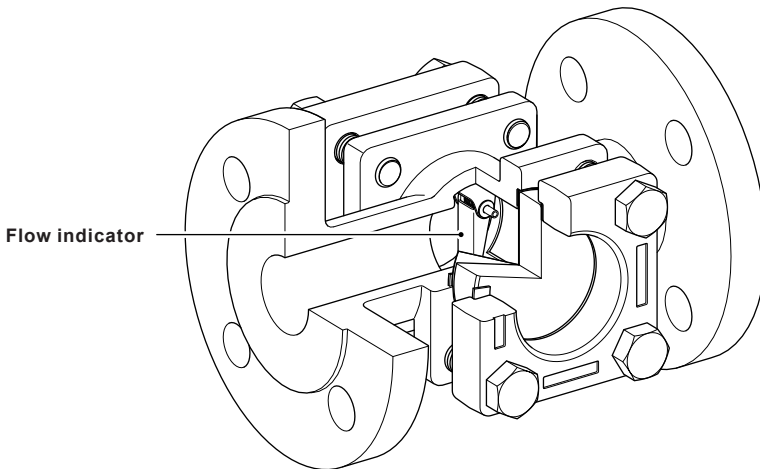

Fig. 4

- Replace the covers (2) and cover bolts (5 - Apply the appropriate grease to SGS40 stainless steel bolting to avoid cold welding) and tighten to the recommended torque (see Table 1).
- After maintenance has been completed, isolation valves should be opened slowly to allow pressure and temperature to build up in a controlled manner.
- Check for leaks.

7. Spare parts

7.1 Spare parts

The spare parts available are shown in solid outline. Parts drawn in a grey line are not supplied as spares.

Available spares

Set of windows and gaskets	3, 4
Set of gaskets	4
Visual flow indicator flap	6
Mica glass protectors	8

* Item 5 is not an available spare.

How to order spares

Always order spares by using the description given in the column headed 'Available spares' and state the size and type of the sight glass.

Example: 1 off Set of windows and gaskets for a Spirax Sarco DN20 SGC40 sight glass.

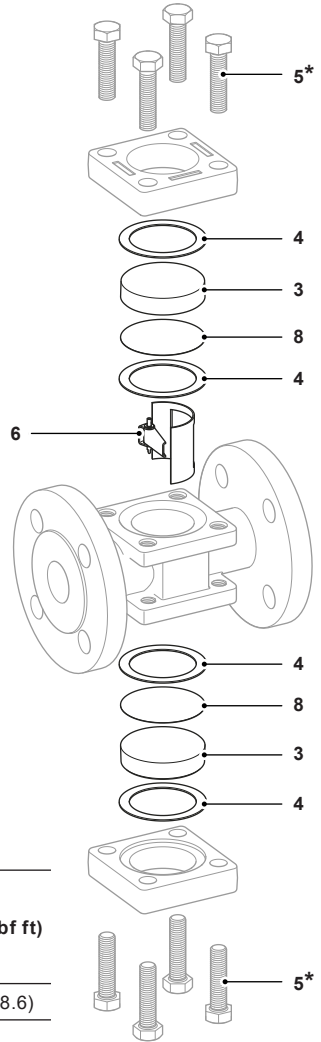



Fig. 5

Table 1 Recommended tightening torques

Item	Size	Quantity	 or mm		N m	(lbf ft)
5	DN15 - DN20	8	17 A/F	M10 x 35	12	(8.6)
	DN25 - DN32 Flanged	8	19 A/F	M12 x 50	28	(20.7)
	DN40 - DN50 and DN32 screwed and SW	8	19 A/F	M12 x 60	38	(28.1)
	DN65 - DN100	8	23 A/F	M16 x 85	132	(97.4)

