

Operating Instructions

Hydrostatic pressure transmitters D84

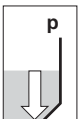
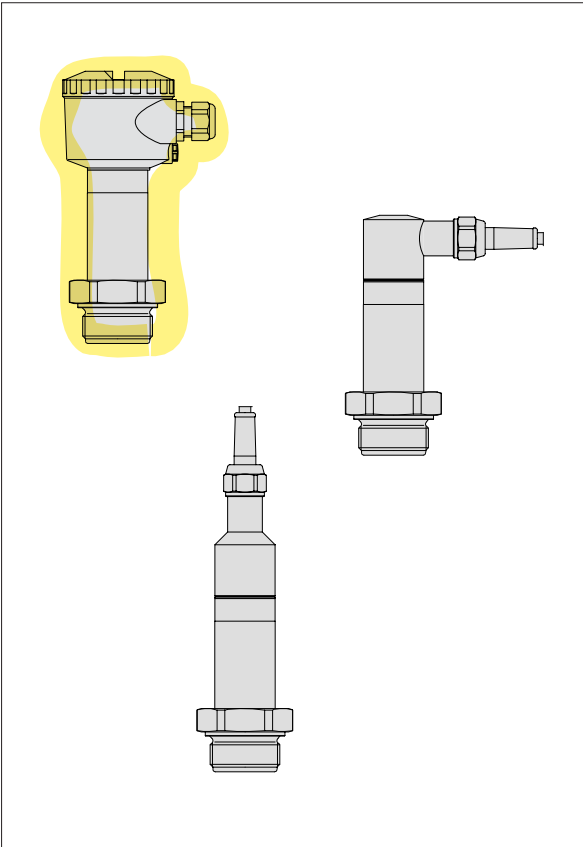

Contents

Safety information	2
Note Ex area	2

1 Product description

1.1 Function and configuration	4
1.2 Electronics version without adjustment	5
1.3 Electronics version with integrated adjustment in connection housing	7
1.4 Electronics for connection to VEGADIS 12	8
1.5 Technical data	9
1.6 Approvals and certificates	13
1.7 Dimensions	14

2 Mounting

2.1 Mounting instructions	18
2.2 Compensation of the atmospheric pressure	18

Safety information

Please read this manual carefully, and also take note of country-specific installation standards (e.g. the VDE regulations in Germany) as well as all prevailing safety regulations and accident prevention rules.

For safety and warranty reasons, any internal work on the instruments, apart from that involved in normal installation and electrical connection, must be carried out only by qualified VEGA personnel.



Note Ex area

Please note the attached safety instructions containing important information on installation and operation in Ex areas.

These safety instructions are part of the operating instructions and come with the Ex approved instruments.

3 Electrical connection

- 3.1 Connection instructions 19
- 3.2 Terminal assignment 20
- 3.3 Connection to external connection housing
VEGABOX 01 21
- 3.4 Connection examples 22

4 Setup

- 4.1 Adjustment structure 23
- 4.2 Sensor without adjustment 24
- 4.3 Sensor with adjustment insert, adjustment
in the sensor 24
- 4.4 Setup with HART® handheld 26
- 4.5 Adjustment with PC directly on the sensor 32

6 Diagnostics 40

7 Instrument modification

- 7.1 Retrofitting the adjustment insert 41
- 7.2 Exchange of hygienic form seal on D84 41

1 Product description

1.1 Function and configuration

The pressure transmitter D84 is an efficient instrument for hydrostatic level measurement. A dry ceramic-capacitive CERTEC® measuring cell is used as pressure sensor element.

Pressure transmitter D84

Measuring cell: dry, ceramic-capacitive

Diaphragm: flush, ceramic

Series: flanged version

Standard application: All kind of level measurements, best suited for food processing and pharmaceutical industries.

The pressure effects a capacitance change on the measuring cell. This capacitance change is detected by an ASIC (Application Specific Integrated Circuit) and converted into a pressure-proportional signal by the integrated electronic module with microcontroller. Precise, high-resolution digital processing of measurement data ensures excellent technical data.

To improve reliability, the functionality of important electronic components is continuously checked, and internal parameters such as sensor value, temperature and operating voltage are closely monitored.

Output signal

The output signal is transferred as a digital or analogue signal from the pressure transmitter to the signal conditioning instrument:

- analogue output signal
 - unstandardised (in conjunction with VEGA signal conditioning instrument)
 - 4 ... 20 mA standardised
- digital output signal (VBUS) for connection to a digital VEGA signal conditioning instrument (VEGAMET 514V, 515V or VEGALOG 571)

1.2 Electronics version without adjustment

Electronics version A:

Pressure transmitter for connection to VEGA signal conditioning instruments

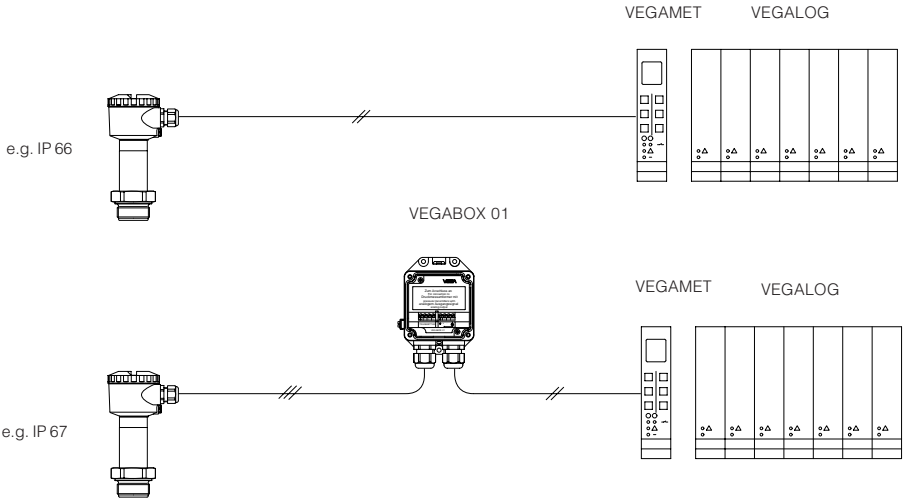

Electronics version B:

Pressure transmitter for connection to VEGA signal conditioning instruments (digital transmission VBUS)

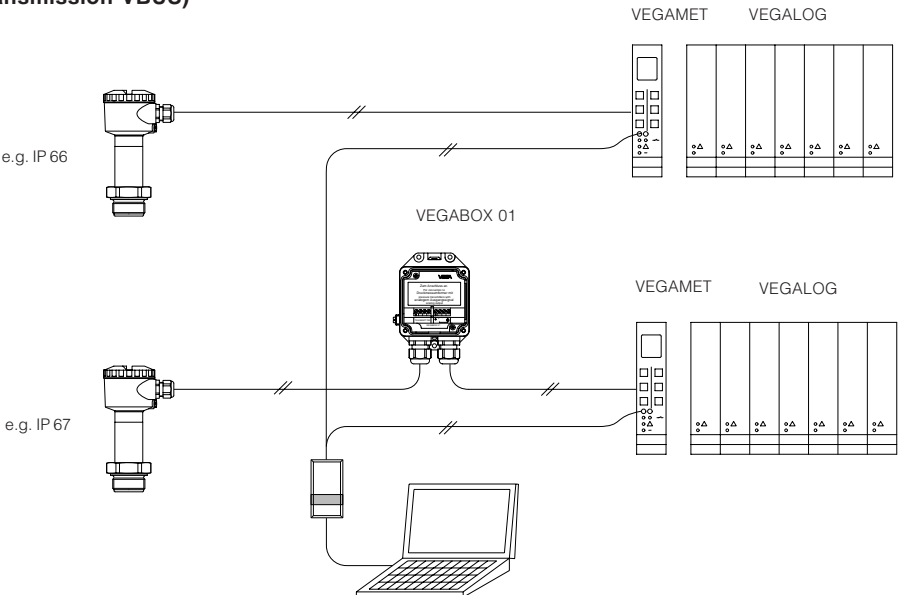

**Electronics version I:
Pressure transmitter 4 ... 20 mA, HART®, VVO**

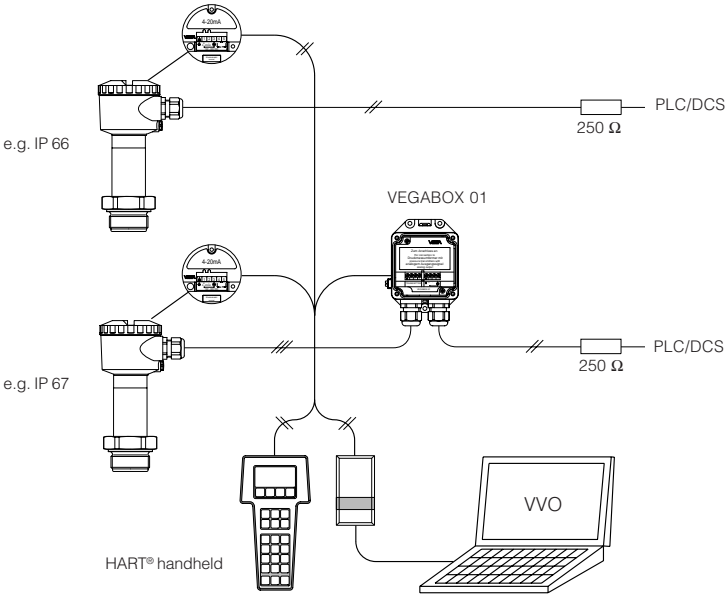

1.3 Electronics version with integrated adjustment in connection housing

Electronics version K:

Pressure transmitter 4 ... 20 mA, HART®, VVO adjustable

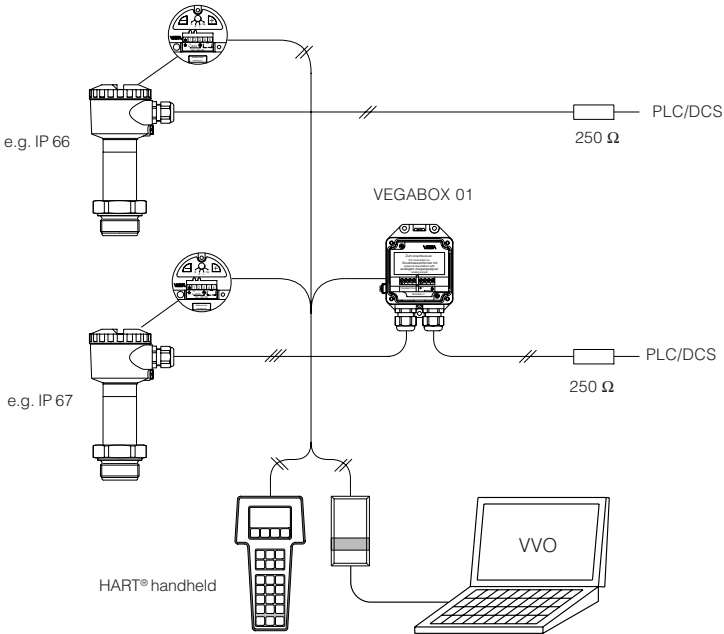

1.4 Electronics for connection to VEGADIS 12

Electronics version L:

Pressure transmitter 4 ... 20 mA, HART®, VVO

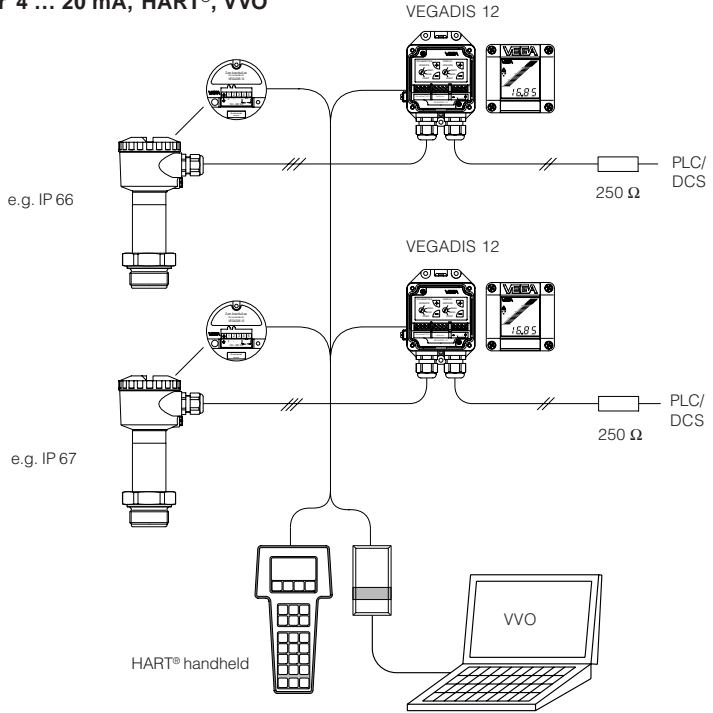

1.5 Technical data

Nominal measuring range	Gauge pr. resistance	Low pr. resistance
Gauge pressure		
0...0.1 bar / 0...10 kPa	15 bar / 1 500 kPa	-0.2 bar / -20 kPa
0...0.2 bar / 0...20 kPa	20 bar / 2 000 kPa	-0.4 bar / -40 kPa
0...0.4 bar / 0...40 kPa	30 bar / 3 000 kPa	-0.8 bar / -80 kPa
0...1.0 bar / 0...100 kPa	35 bar / 3 500 kPa	-1.0 bar / -100 kPa
0...2.5 bar / 0...250 kPa	50 bar / 5 000 kPa	-1.0 bar / -100 kPa
0...5.0 bar / 0...500 kPa	65 bar / 6 500 kPa	-1.0 bar / -100 kPa
0...10.0 bar / 0...1 000 kPa	90 bar / 9 000 kPa	-1.0 bar / -100 kPa
0...20.0 bar / 0...2 000 kPa	130 bar / 13 000 kPa	-1.0 bar / -100 kPa
0...40.0 bar / 0...4 000 kPa	200 bar / 20 000 kPa	-1.0 bar / -100 kPa
0...60.0 bar / 0...6 000 kPa	300 bar / 30 000 kPa	-1.0 bar / -100 kPa
-0.05...+0.05 bar / -5...+5 kPa	15 bar / 1 500 kPa	-0.2 bar / -20 kPa
-0.1...+0.1 bar / -10...+10 kPa	20 bar / 2 000 kPa	-0.4 bar / -40 kPa
-0.2...+0.2 bar / -20...+20 kPa	30 bar / 3 000 kPa	-0.8 bar / -80 kPa
-0.5...+0.5 bar / -50...+50 kPa	35 bar / 3 500 kPa	-1.0 bar / -100 kPa
-1.0...0.0 bar / -100...0 kPa	35 bar / 3 500 kPa	-1.0 bar / -100 kPa
-1.0...+1.5 bar / -100...+150 kPa	50 bar / 5 000 kPa	-1.0 bar / -100 kPa
-1.0...+4.0 bar / -100...+400 kPa	65 bar / 6 500 kPa	-1.0 bar / -100 kPa
-1.0...+10.0 bar / -100...+1 000 kPa	90 bar / 9 000 kPa	-1.0 bar / -100 kPa
-1.0...+20.0 bar / -100...+2 000 kPa	130 bar / 13 000 kPa	-1.0 bar / -100 kPa
-1.0...+40.0 bar / -100...+4 000 kPa	200 bar / 20 000 kPa	-1.0 bar / -100 kPa
-1.0...+60.0 bar / -100...+6 000 kPa	300 bar / 30 000 kPa	-1.0 bar / -100 kPa
Absolute pressure		
0...1.0 bar / 0...100 kPa	35 bar / 3 500 kPa	
0...2.5 bar / 0...250 kPa	50 bar / 5 000 kPa	
0...5.0 bar / 0...500 kPa	65 bar / 6 500 kPa	
0...10.0 bar / 0...1 000 kPa	90 bar / 9 000 kPa	
0...20.0 bar / 0...2 000 kPa	130 bar / 13 000 kPa	
0...40.0 bar / 0...4 000 kPa	200 bar / 20 000 kPa	
0...60.0 bar / 0...6 000 kPa	300 bar / 30 000 kPa	

Mechanical data

Materials, wetted parts

Process connection
Diaphragm

stainless steel 1.4435 or 1.4571
sapphire-ceramic®

Materials, non-wetted parts

Housing
External connection housing
Ground terminal
Window of the display module

Alu (seawater resistant) Pe-powder coated,
stainless steel 1.4571
high resistance plastic PBT (Polyester)
stainless steel 1.4305
safety glass

Weights

Basic weight without housing	approx. 1.6 kg
External housing	approx. 400 g

Adjustment and display elements

Pressure transmitter	without adjustment elements
- terminal insert	2 keys, 1 rotary switch
- adjustment insert	

Electrical data

Adjustment ranges

Zero	adjustable from -20 ... +95 % of nominal range
Span	adjustable from 3.3 ... 120 % of nominal range

Supply and signal circuit (analogue transmission, 4 ... 20 mA), electronics version A, C, I and K

Supply voltage	12 ... 36 V DC
permissible residual ripple	$U_{ss} \leq 1 \text{ V}$
- at 100 Hz ... 10 kHz	$U_{ss} \leq 10 \text{ mV}$
Output signal	
- terminal insert	- analogue transmission (not standardised)
	- 4 ... 20 mA
- adjustment insert	4 ... 20 mA (adjustable)
Current limitation	approx. 22 mA
Fault signal	22 mA (3.6 mA)
Integration time	0 ... 10 s
Rise time	70 ms ($t_i = 0 \text{ sec}$; 0 ... 63 %)
Max. permissible load	see load diagram:

Load in Ω

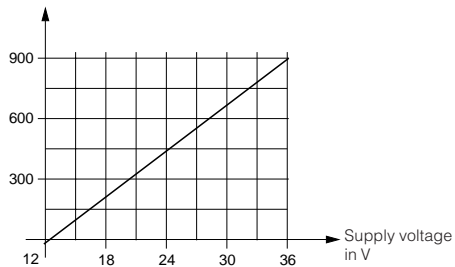

Supply and signal circuit (analogue transmission, 4 ... 20 mA), additional data for electronics version L

Supply voltage for pressure transmitters in conjunction with VEGADIS 12	
- without display	12 ... 36 V DC
- with display	17 ... 36 V DC
Max. input current	150 mA
Current signal range	3.5 ... 22 mA
Max. permissible load	see load diagram:

Load diagram with display

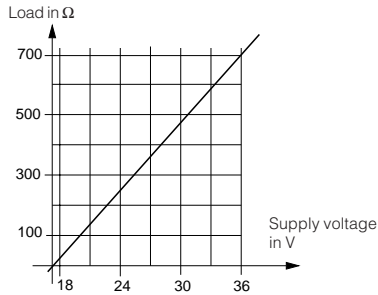

Supply and signal circuit on VEGA signal conditioning instruments (digital signal transmission VBUS), additional data for electronics version B

Supply voltage	25 ... 36 V DC, from VEGAMET (VBUS) or from VEGALOG 571 with EV input card
Data transmission	digital (VBUS)
Connection cable	2-wire screened
Cable length	max. 1000 m

Integrated overvoltage protection (option)

Nominal response DC voltage	
- protective diode	40 V
- gas separator	650 V
Nominal leakage current	
- gas separator	20 kA

Connection cables

Cable entry	
- housing	2 x M20x1.5 (for cable ø 5...9mm or 9...12mm)
- external connection housing	2 x M20x1.5 (for cable ø 5...9mm or 9...12mm)
Screw terminals	
- sensor	for wire cross-sections of up to 2.5 mm ²
- external connection housing	for wire cross-sections of up to 2.5 mm ²

Protective measures ¹⁾

Protection	IP 66, IP 67, IP 68
VEGABOX 01	IP 66 and IP 67
Protection class	III
Overvoltage category	III

Accuracy (similar to DIN 16 086, DIN V 19 259 - 1 and IEC 770)**Deviation**

Reference conditions (acc. to IEC 770)	
- temperature	15°C ... 30°C
- humidity	45 % ... 75 %
- air pressure	86 kPa ... 106 kPa
Determination of characteristics	limit point adjustment acc. to DIN 16 086
Characteristics	linear
Deviation in characteristics	incl. hysteresis and repeatability
- Turn Down 1 : 1	< 0.25 % with accuracy class 0.25 < 0.1 % with accuracy class 0.1
- Turn Down up to 1 : 5	typ. < 0.3 % with accuracy class 0.25 typ. < 0.1 % with accuracy class 0.1
- Turn Down up to 1 : 10	typ. < 0.4 % with accuracy class 0.25 typ. < 0.2 % with accuracy class 0.1

Influence of the ambient temperature

Average temperature coefficient of the zero signal ²⁾	
- Turn Down 1 : 1	< 0.15 %/10 K with accuracy class 0.25 < 0.05 %/10 K with accuracy class 0.1
- Turn Down up to 1 : 5	typ. < 0.225 %/10 K with accuracy class 0.25 typ. < 0.075 %/10 K with accuracy class 0.1
- Turn Down up to 1 : 10	typ. < 0.3 %/10 K with accuracy class 0.25 typ. < 0.1 %/10 K with accuracy class 0.1

Long-term stability

Long-term stability of the zero signal ³⁾	< 0.1 % per 2 years
--	---------------------

Other actuating variables

Calibration position	upright, diaphragm points downwards
Influence of the installation position	< 0.2 mbar/20 Pa
Vibration resistance	mechanical vibrations with 4 g and 5 ... 100 Hz, tested acc. to the regulations of German Lloyd GL-characteristics 2

¹⁾ Maintaining the housing protection IP 66 or IP 67 requires the use of a seal that correctly fits the cable in the cable entry. If the supplied seal does not fit, a suitable seal must be provided by the customer.

²⁾ In compensated temperature range of 0°C ... +80°C, reference temperature 20°C.

³⁾ Acc. to IEC 770, item 6.3.2 relating to the nominal range.

Operating conditions

Ambient conditions

Ambient temperature	-40°C ... +85°C
- with indicating module	-10°C ... +60°C
Storage and transport temperature	-50°C ... +100°C
Product temperature	
- Viton seal	-20°C ... +100°C
- EPDM seal	-40°C ... +100°C
- Kalrez seal	0°C ... +100°C

1.6 Approvals and certificates

Approvals

- Ex Zone 2
- CENELEC EEx ia IIC
- ATEX II 1G EEx ia IIC

If the use of approved instruments is required for certain applications, the appropriate official documents (test reports, test certificates and conformity certificates) must be observed. These are supplied with the respective instrument.

CE conformity **CE**

D84 pressure transmitters meet the requirements of EMC (89/336/EWG) and NSR (73/23/EWG). Conformity has been judged acc. to the following standards:

EMC	Emission	EN 50 081 - 1: 1992
	Susceptibility	EN 50 082 - 2: 1995
NSR		EN 61 010: 1993

NAMUR regulations

Full compliance with the NAMUR regulations NE21 and NE 43.

1.7 Dimensions

Housings

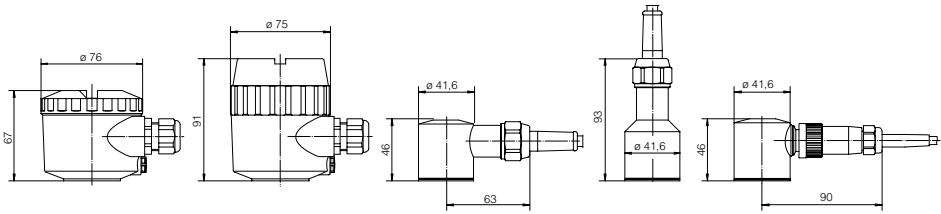

Process connections D84

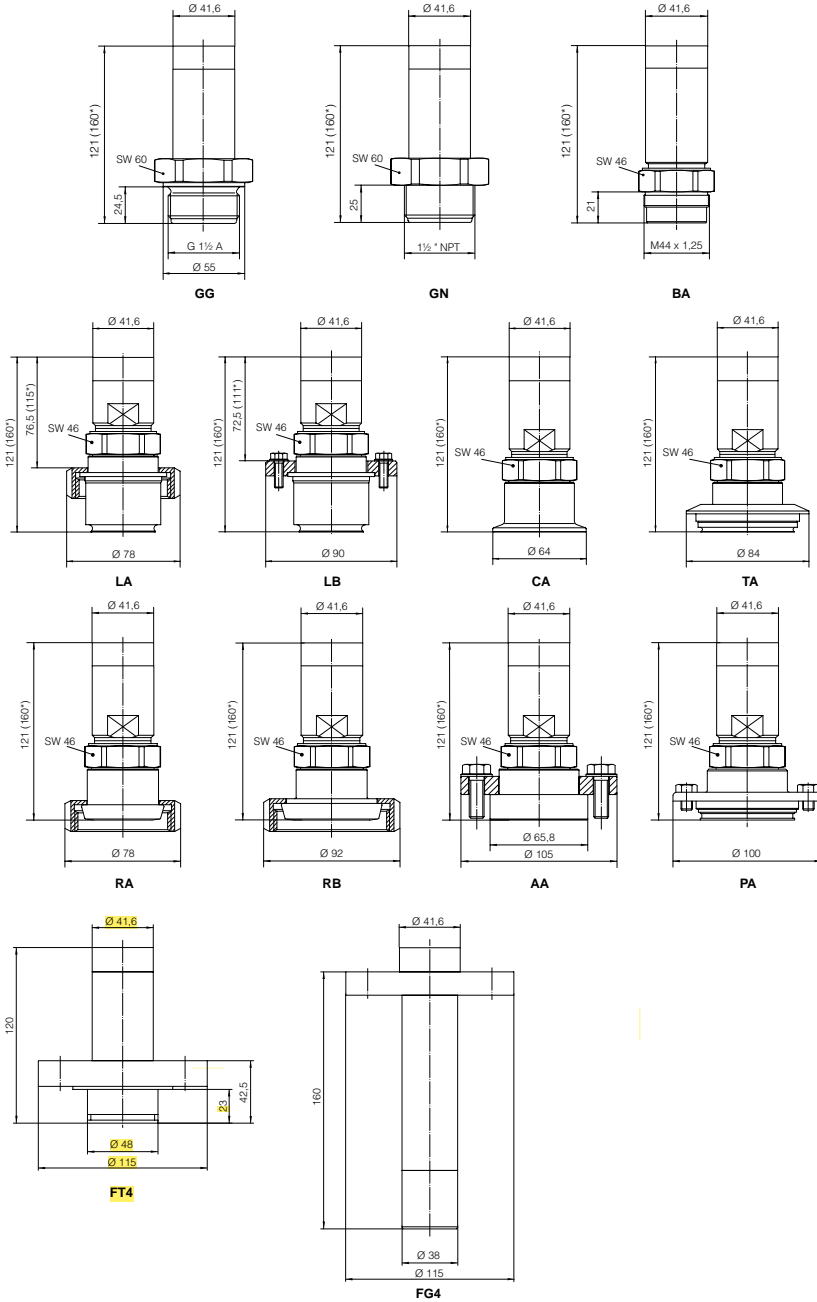

*) VBUS version

Pressure transmitter accessory

Welded socket

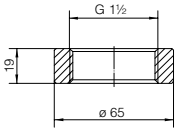

GG

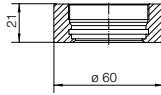

BA

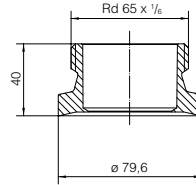

LA

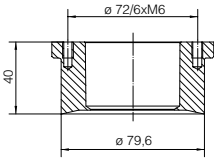

LB

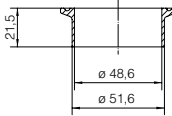

CA

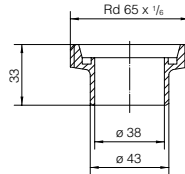

RA

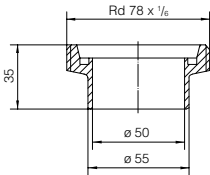

RB

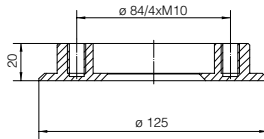

AA

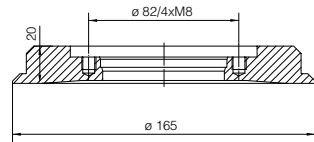

PA

VEGABOX 01

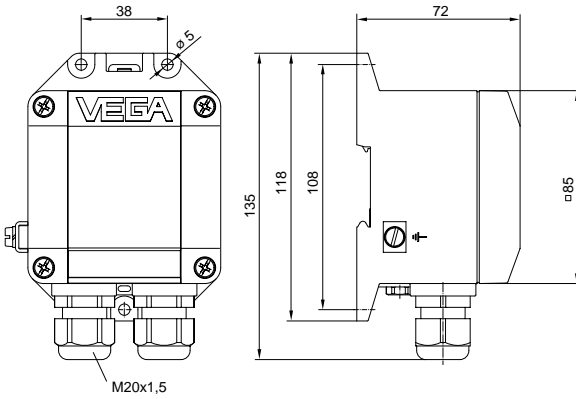

with protective cover

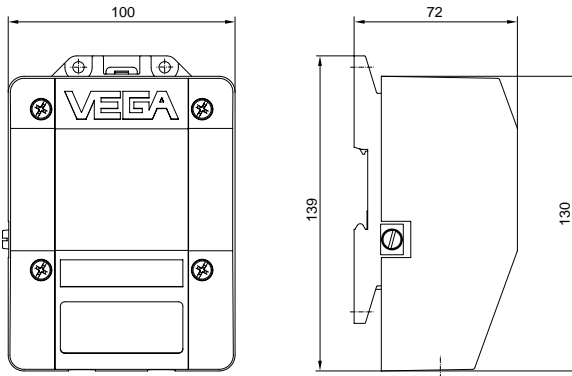

2 Mounting

2.1 Mounting instructions

The pressure transmitter can be mounted in any position. Cable entries must point downwards to avoid moisture ingress. For this purpose, the housing can be rotated by 330° in relation to the mounting part.

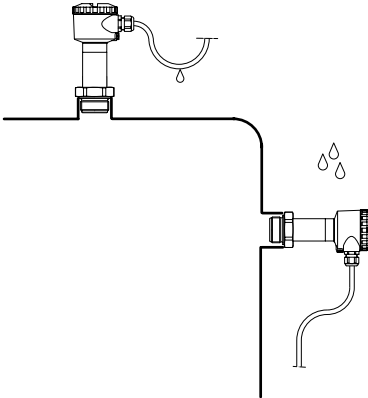

An appropriate connection seal must be used for mounting. This seal is either supplied with the pressure transmitter or must be provided by the customer.

2.2 Compensation of the atmospheric pressure

On instruments for gauge pressure measurement, the atmospheric pressure is compensated via a breather facility integrated in the housing.

Pressure transmitter with housing

- via an integrated breather facility (PTFE use ¹⁾), protection IP 66
- via the capillaries of a special cable connected to the terminals, protection IP 67

Pressure transmitter with direct cable outlet

- via the capillaries of a special cable connected to the terminals, protection IP 68

We recommend leading the special cable into the external connection housing VEGABOX 01 (accessory) and carrying out the pressure compensation via the integrated breather facility there.

External connection housing

Observe the following instructions:

- as a rule, there must be the same atmospheric pressure on the breather facility as on the vessel
- the pressure compensation must be done in a dry environment
- with vertical wall mounting, cable entries must point downward to avoid moisture ingress and buildup on the breather facility.

¹⁾ air permeable and humidity blocking

3 Electrical connection

3.1 Connection instructions

The electronics in the pressure transmitter requires a supply voltage of 12 ... 32 V DC. It is designed in two-wire technology, i.e. the supply voltage and the digital output signal are led via the same two-wire cable to the terminals.

This external energy is provided via a separate power supply unit, e.g.:

- power supply unit VEGASTAB 690
- processing unit with integrated DC voltage source (e.g. active PLC input)
- VEGAMET, VEGALOG or VEGADIS 371

Make sure that the external energy source is reliably separated from the mains circuits acc. to DIN VDE 0106, part 101. The above-mentioned VEGA devices meet this requirement and protection class III is therefore guaranteed.

The external energy source must provide a terminal voltage of at least 12 V on the transmitter. The actual terminal voltage on the transmitter depends on the following factors:

- output voltage U_H of the external energy source under nominal load.
- electrical resistance of the connected instruments in the circuit (see connected instruments, load resistance).

Note the following instructions for electrical connection:

- Connection must be made according to the country-specific installation standards (e.g. in Germany acc. to the VDE regulations).
- The terminal voltage must not exceed 36 V, to avoid damage to the electronics.
- The electrical connection must have a protective measure against polarity reversal.
- Connection of Ex sensors only by qualified personnel.
- The wiring between pressure transmitter and power supply can be made with standard two-wire cable.

- If strong electromagnetic interference is expected, screened cable is recommended. The screening must be done on both ends. Note the installation regulations for use in Ex areas.
- In case of overvoltages, we recommend the use of pressure transmitters with integrated overvoltage protection or the installation of VEGA overvoltage arresters.
- In the cable entry, a seal correctly fitting the cable should be used.

Safety information for Ex applications

As a rule, do all connecting work in the complete absence of line voltage. Always switch off the power supply before you carry out connecting work on the sensors. Protect yourself and the instruments.

Qualified personnel

Instruments used in Ex areas must be installed only by qualified personnel. The qualified personnel must observe and understand the mounting regulations and the supplied type approval certificates and conformity certificates.

If an instrument is used in hazardous areas, the respective regulations, conformity certificates and type approvals of the sensors, separators or safety barriers must be noted (e.g. DIN VDE 0165).

Sensors used in Ex areas must be connected only to intrinsically safe circuits. The permissible electrical values are stated in the conformity certificate or the type approval certificate.

Intrinsically safe circuits with more than one active instrument (instrument delivering electrical energy) are not allowed. Please note the special installation regulations (DIN VDE 0165).

Certain pressure transmitters are provided with a warning label informing of measures to be taken to avoid the danger of electrostatic discharge. Note the content of the warning label.

3.2 Terminal assignment

Direct cable outlet

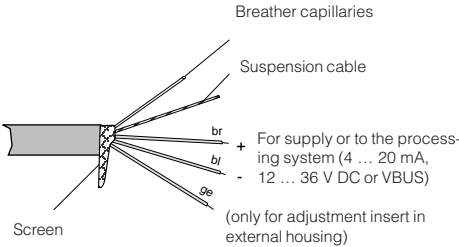

Electronics version A

for connection to VEGA signal conditioning instruments

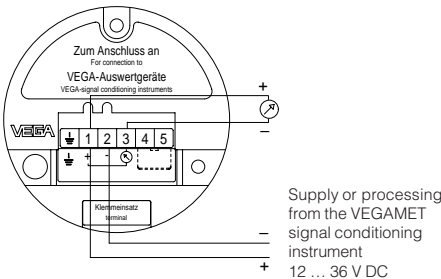

Electronics version B

Digital output signal for connection to a digital VEGA signal conditioning instrument (VBUS)

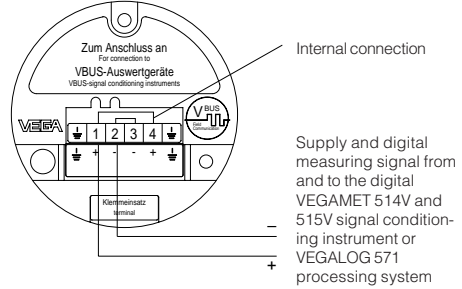

Electronics version I

4 ... 20 mA output signal, remote parameter setting through PC and HART® handheld

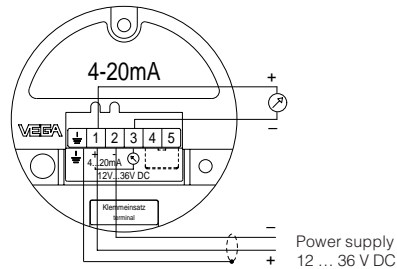

Electronics version K

4 ... 20 mA output signal with integrated adjustment and remote parameter setting through PC and HART® handheld

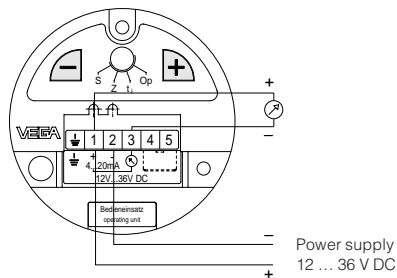

Electronics version L

4 ... 20 mA output signal with adjustability via the external connection housing VEGADIS 12, as well as remote parameter adjustability via PC and HART® handheld

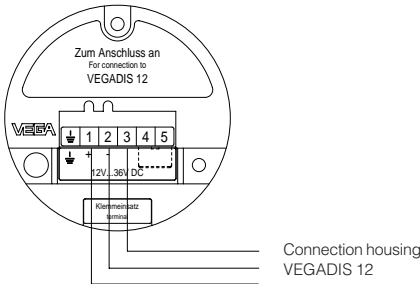

3.3 Connection to external connection housing VEGABOX 01

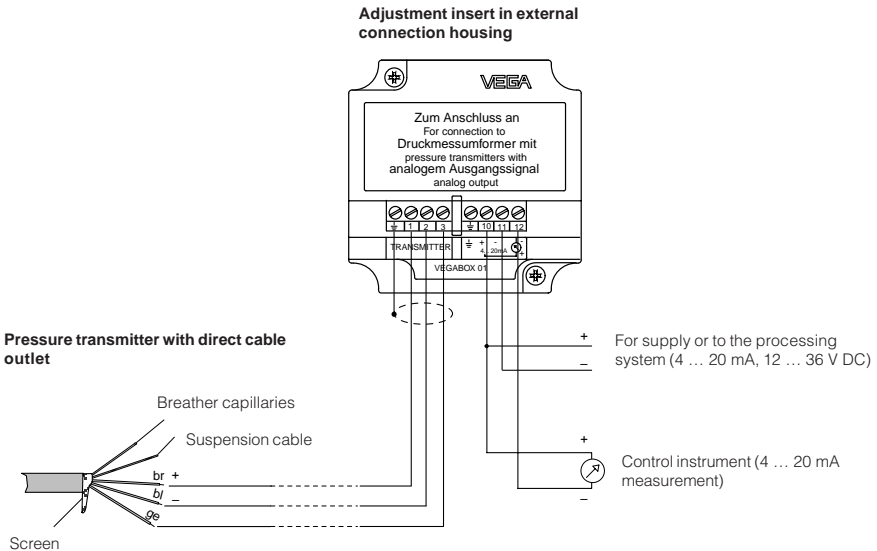

3.4 Connection examples

Note:

An ammeter for local control of the output current can be connected to terminals 1 and 3. This measurement can be carried out during operation without interrupting the supply cable.

The following connection examples are valid for direct connection to the terminals of the pressure transmitter. When using the external connection housing, the connection is made to the respective terminals of the housing.

Supply through a power supply unit

Processing is done by an indicating instrument.

Ammeter for local control

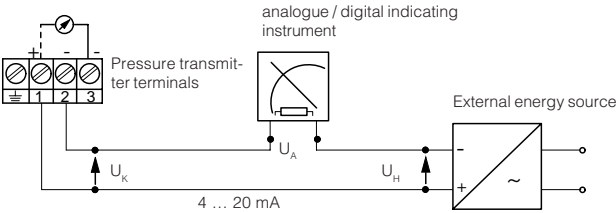

Supply through a VEGA signal conditioning instrument

Standard wiring for non-standardised output.

Ammeter for local control

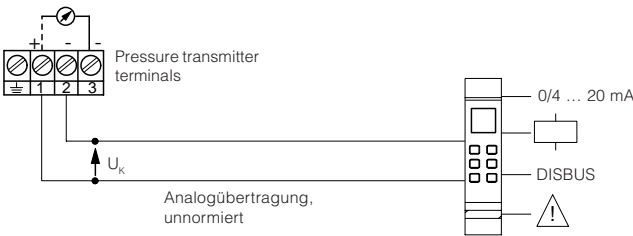

Supply through a PLC with active input circuit

Processing is done by the PLC

Ammeter for local control

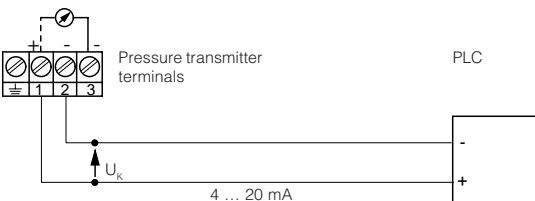

4 Setup

4.1 Adjustment structure

The hydrostatic pressure transmitters come with or without adjustment capability.

After connection to the supply voltage, the electronics carries out a self-test (approx. 2 sec.) and the current in this signal circuit (sensors with analogue output signal) takes on a value of > 21.6 mA.

Sensors with adjustment (electronics version A and C)

Sensors with electronics version A deliver a pressure-proportional current as measured value and are not adjustable. All settings such as adjustment, density correction etc. are carried out via the signal conditioning instrument. The sensors with electronics version C come preadjusted according to the measuring range of the sensor (factory setting). In unpressurised condition, they consume a current of 4 mA. With a pressure at the measuring range final value, they consume a current of 20 mA.

Sensors with adjustment insert in the sensor (electronics version K)

The adjustment insert with selection switch allows:

- zero adjustment
"z" = empty adjustment
- span adjustment
"s" = full adjustment
- adjustment of an integration time (time) "ti"

Adjustment in external connection housing VEGADIS 12 (electronics version L)

The adjustment insert with selection switch (VEGADIS 12 with display) allows:

- zero adjustment
- span adjustment
- adjustment of an integration time (time)
- adjustment of a value for zero point (empty)
- adjustment of a value for span (full)
- adjustment of the decimal point for the displayed value

Adjustment with HART® handheld (electronics version I, K and L)

The hydrostatic pressure transmitters with electronics version I, K and L can be adjusted with the HART® handheld like other HART® capable instruments. A manufacturer specific DD (Device Description) is not necessary. The sensors work with the HART® standard menus.

Adjustment of VEGA signal conditioning instrument VEGAMET (electronics version A and B)

Electronics version A delivers a non-standardised output signal to a VEGAMET with analogue input.

Electronics version B transfers the measured value digitally (VBUS) to a digital VEGAMET (514V, 515V, 614V).

The signal conditioning instrument itself, as well as the pressure transmitter, can be operated by means of the standard six-key adjustment field (with clear dialog text display) on the signal conditioning instrument.

Adjustment with PC and adjustment program VVO (electronics version B, I, K and L)

With the adjustment program VVO (VEGA Visual Operating) on the PC you can conveniently adjust the pressure transmitters with electronics version B, I, K and L. The PC communicates with the sensor through the interface converter VEGACONNECT 2 or the standard RS 232 interface cable. A digital adjustment signal is superimposed on the signal and supply cable. The adjustment can be carried out from any location on the signal cable, on the sensor directly, on the signal conditioning instrument or on the VEGALOG processing system.

4.2 Sensor without adjustment

Sensors with electronics version C have no adjustment capability and come preset to the stated measuring range.

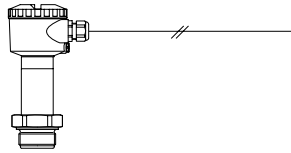

4.3 Sensor with adjustment insert, adjustment in the sensor

Sensors with electronics version D and K are equipped with an adjustment insert.

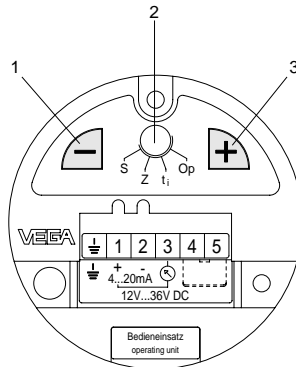

- 1 Reduce value
- 2 Rotary switch
- 3 Increase value

With the rotary switch you can select four switch positions:

- s - span
- z - zero
- ti - time (integration time)
- Op - operate (operating status)

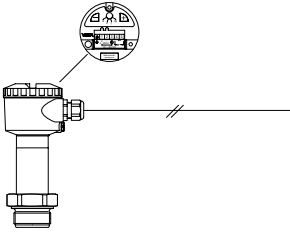

Adjustment

For adjustment of zero and span, an ammeter must be connected to terminals 1 and 3. The measured value is identical to the output current.

1 Adjustment of zero

(e.g. process pressure zero or empty vessel)

- Set rotary switch to zero.
- By pushing the "+" and "-" keys simultaneously, the current jumps directly to 4 mA or you can adjust a current of 4 mA with the "+" and "-" keys.

Adjustment range of zero:

-20 % ... +95 % of nominal measuring range
(corresponds to a turn up of up to +95 %)

2 Adjustment of span

(e.g. process pressure or level at maximum)

- Set rotary switch to span.
- By pushing the "+" and "-" keys simultaneously, the current jumps directly to 20 mA or you can adjust a current of 20 mA with the "+" and "-" keys.

Adjustment range of span:

3.3 % ... 120 % of nominal measuring range
(corresponds to a turn down 1 : 30)

Note:

- A modification of zero does not influence the span, i.e. the measuring range final value is simply shifted.
- It is also possible to adjust currents for partial fillings or partial pressures, e.g. 8 mA for 25 % and 16 mA for 75 %. The pressure transmitter then automatically calculates the values for 0 % or 100 % (only possible with a level difference >3.3 %).

Integration time

An integration time t_i of 0 ... 10 s can be adjusted to damp pressure shocks.

Procedure

- Set rotary switch to t_i .
- By pushing the "-" 10 times, make sure that the integration time is set to 0 s.
- For each 1 s of requested integration time, the "+" key has to be pushed once.

4.4 Setup with HART® handheld

Sensors with electronics versions I, K and L can be set up with the HART® handheld. A special DD (Data Device Description) is not necessary. Just connect the HART® handheld to the sensor signal cable after you have connected the sensor to supply voltage.

Note:

If the resistance of the voltage supply is less than $250\ \Omega$, a resistor must be looped into the signal/connection cable during adjustment. The digital adjustment and communication signals would otherwise be short-circuited through insufficient resistance of e.g. the supply voltage source or the processing system. In such case, communication with the sensor would not be ensured. Simply connect the adjustment resistor in parallel to the connection socket of the HART® handheld.

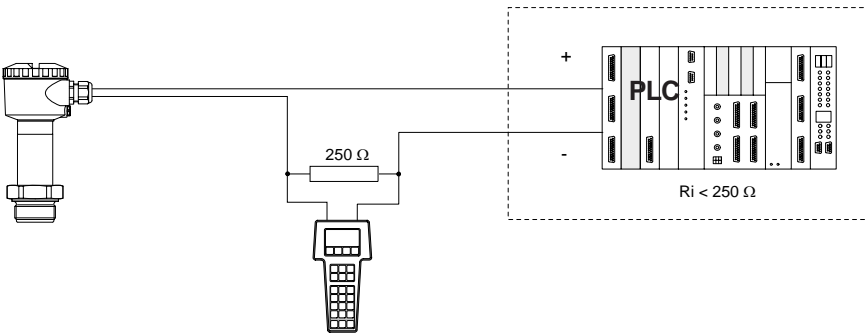

The most important adjustment steps

On the following four pages you see a menu schematic of the HART® handheld in conjunction with pressure transmitters D80 ... D87. The most important adjustment steps are marked in the menu schematic with the letters A ... D. If you are not familiar with HART® handheld, please note:

After entering a parameter, first push the "ENTER" key. The adjustment is saved in the handheld, but not in the sensor itself.

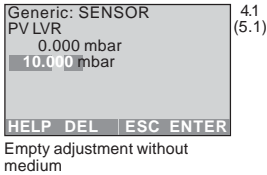

After you have pushed "ENTER", you have to push "SEND" (here in the example for the min. adjustment), to transfer the input to the sensor.

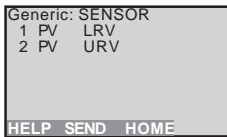

After pushing "SEND", a warning is displayed that you are about to change device output and for safety reasons, you should switch your system to manual operation. Push "OK" and the adjustment is now transferred to the sensor.

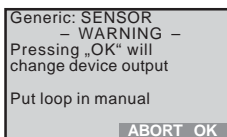

After a moment, you are asked to switch the system from manual to automatic operation. Confirm with "OK"

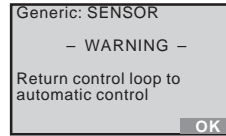

and then with "HOME".

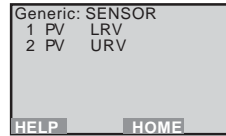

You are now in the initial menu.

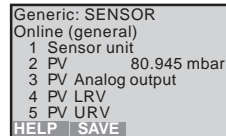

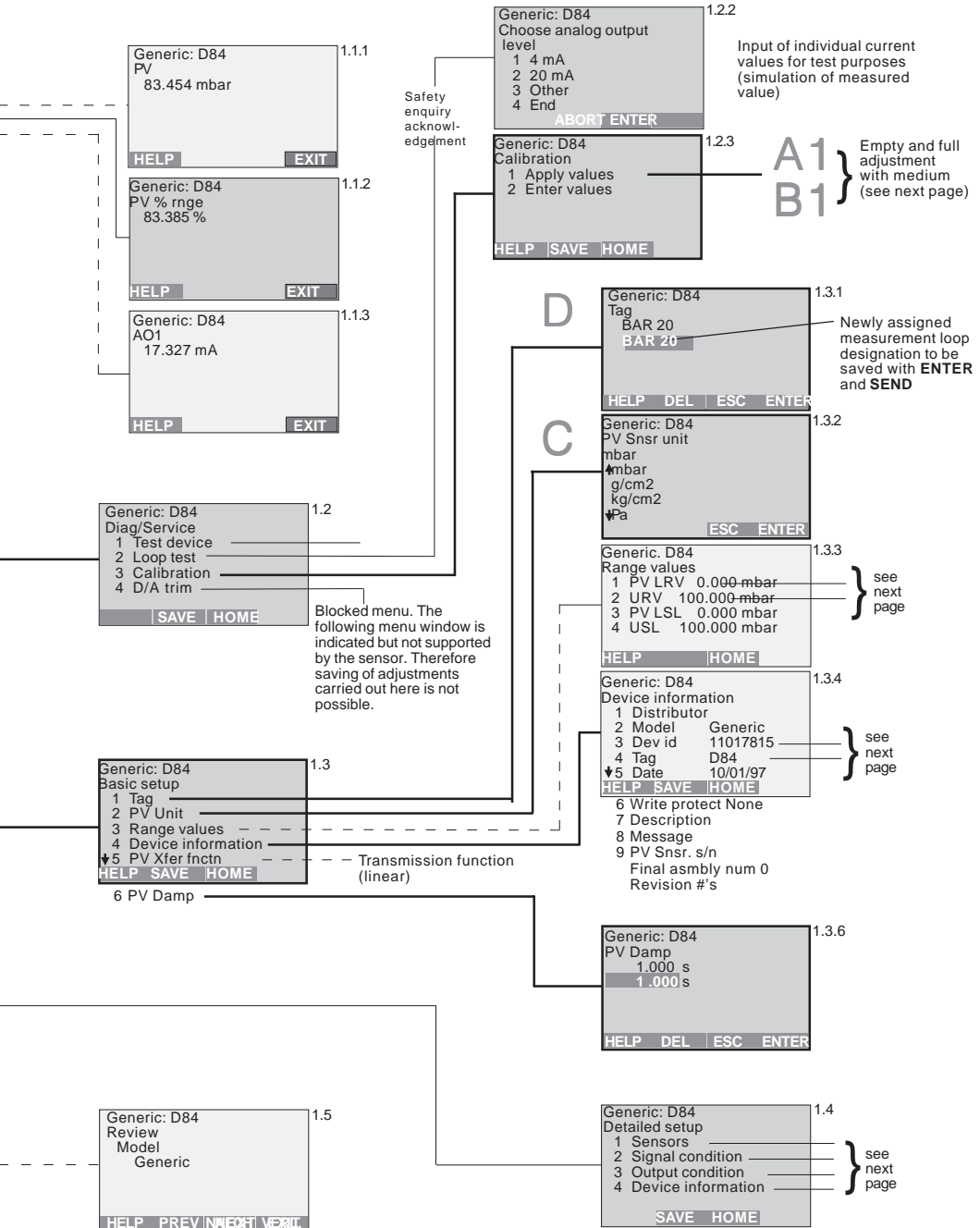

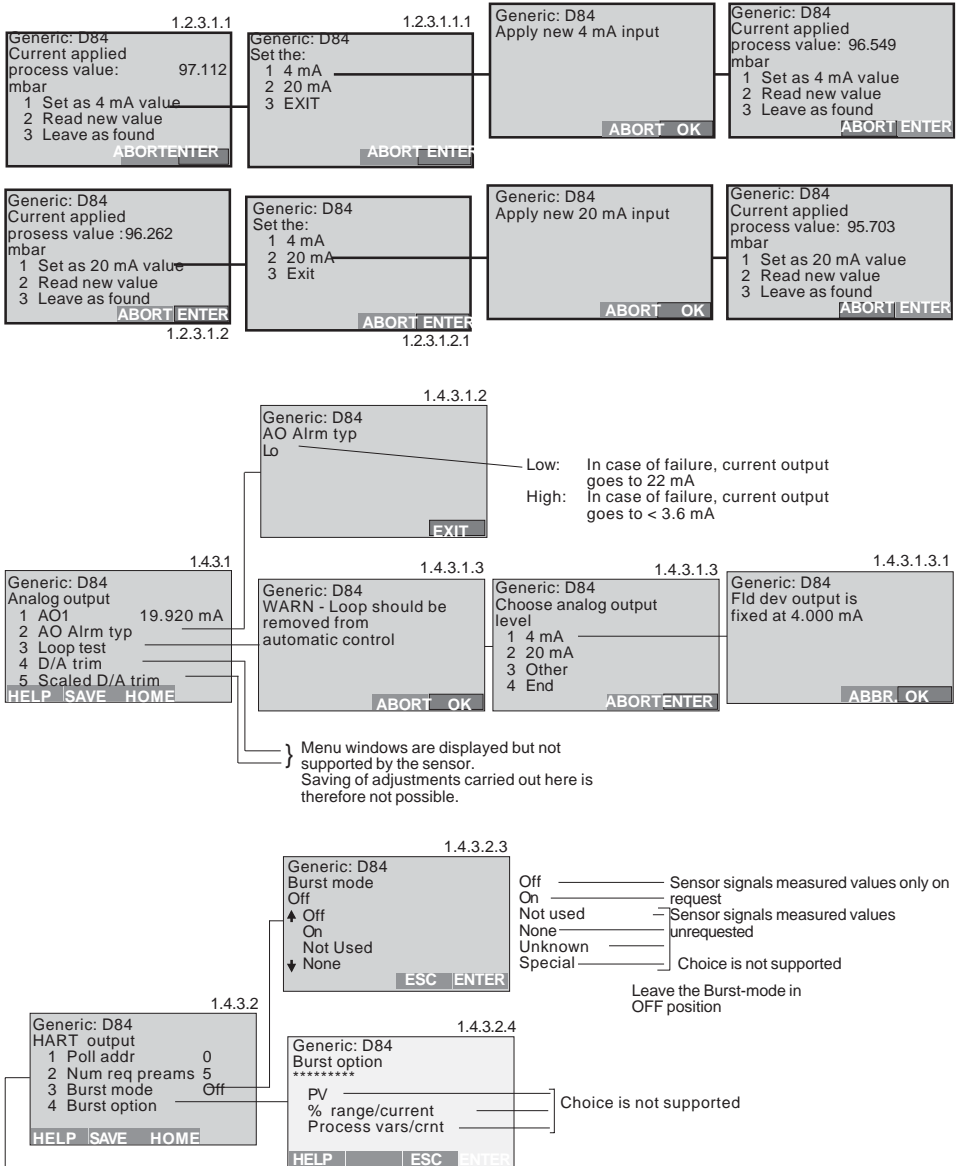

Note:

After entering a parameter, push "ENTER" and then "SEND".
 Confirm the message to switch over to manual operation with "OK".
 Confirm the message to reset to automatic operation also with "OK".
 Only then will the adjustment be stored in the sensor and take effect.

5.5 Adjustment with PC directly on the sensor

(electronics versions I, K and L)

For connection of the PC to the sensor, the interface converter VEGACONNECT 2 is required.

Connection of the PC to the sensor

Insert VEGACONNECT into the serial interface of the PC and insert the two-wire cable of VEGACONNECT into the CONNECT socket of the sensor.

Connection of the PC to the signal cable

Connect the two-wire cable of VEGACONNECT 2 to the signal cable leading to the sensor.

Connection configuration with pressure transmitter directly on active PLC

(electronics versions I, K and L)

- Two-wire technology, power supply from active PLC.
- Output signal 4 ... 20 mA (passive).
- Adjustment with PC, HART® handheld or adjustment insert located in the sensor or in the external connection housing.

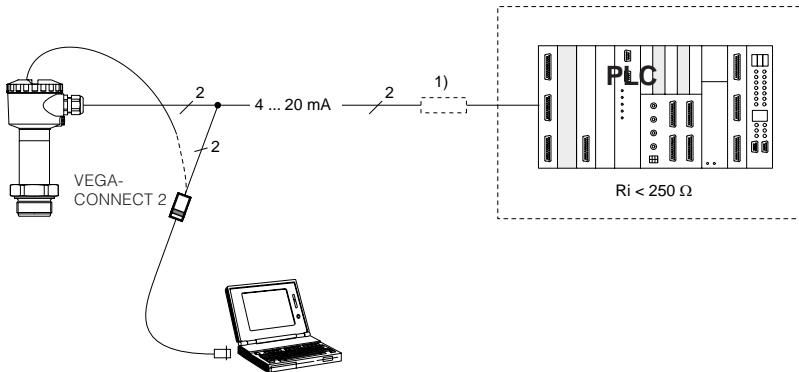

- ¹⁾ If the resistance of the processing system (PLC) connected to the 4 ... 20 mA output is less than 200 Ω, a resistor of 250 Ω must be connected to the connection cable during adjustment.

The digital adjustment signal would be considerably damped or short-circuited through insufficient resistance of a connected processing system, and digital communication with the PC would not be ensured.

If you have already connected the PC with the adjustment software VVO to your measuring system,

- first switch on the power supply of the connected sensor
- switch on the PC and start the adjustment software VVO.

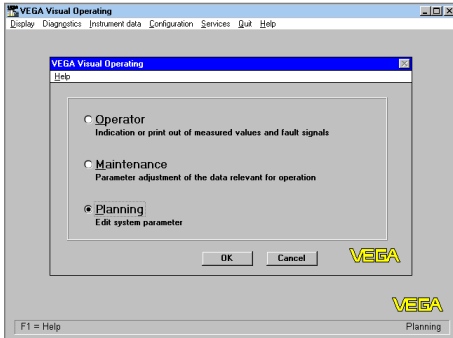

- Choose with the arrow keys or the mouse the item "**Planning**" on the entrance screen and click to "**OK**".

You are asked for user identification.

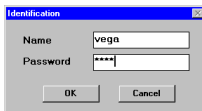

- Enter under name "**VEGA**".
- Also enter "**VEGA**" under password.

The adjustment program (VVO), called in the following VVO, gets into contact with the connected sensor...

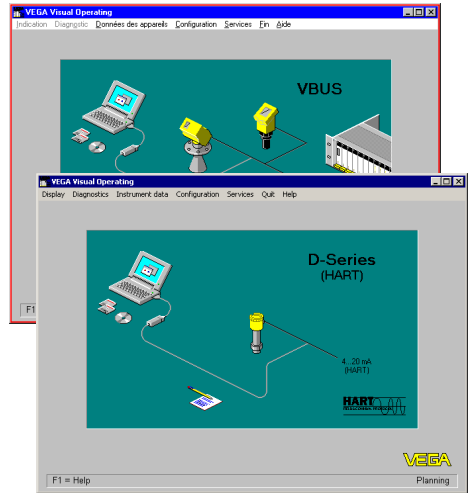

...and indicates after a few seconds if and with which sensor a connection exists.

The preset user identification can be modified later in the menu "**User access**".

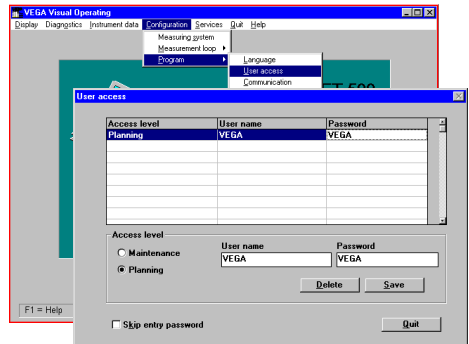

Note:

If you connect the adjustment software (VVO) to a sensor from which data has already been saved, you are asked if the saved data should be transferred to the sensor or if you want to transfer the sensor data to the database of VVO (the available data of the current sensor will be overwritten).

- If you don't get communication with the sensor, check the following:
- Is the sensor being supplied with sufficient voltage (min. 12 V)?
 - When VEGACONNECT 2 is connected to the signal cable, is the load resistance 250 ... 350 Ω?

Configuration

- Choose the menu "Configuration/Measuring system", to get further information on the sensor type, the software version of the sensor, measuring unit, the measurement loop designation etc.

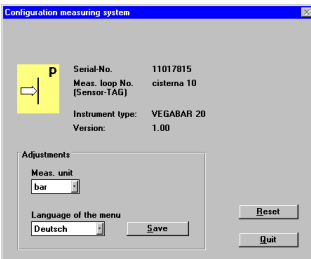

- Click to "Quit".
- Click to the menu "Configuration/Measurement loop/Modify". This is the first step of sensor setup.

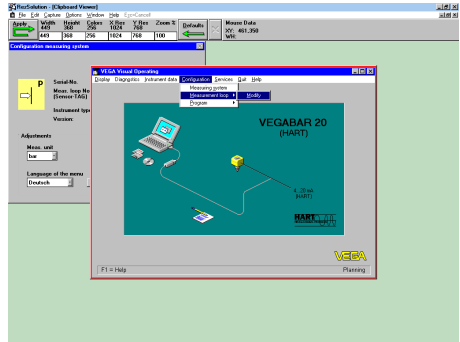

In the menu "Modify meas. loop configuration" you can give a name (e.g. vessel 10) and a description (e.g. cleaning detergent) to the measurement loop in place of the sensor number. This will make your entire measuring system more understandable.

- Now enter in this menu whether a level, a distance or a gauge should be measured.

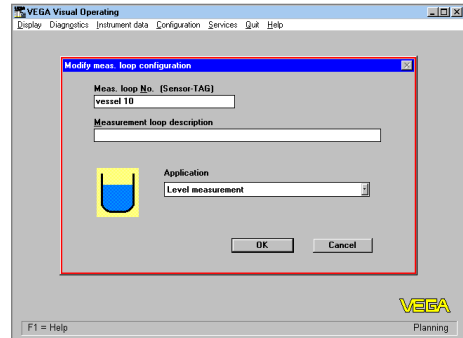

- Confirm the adjustment with "OK" and after saving you are again in the initial menu.

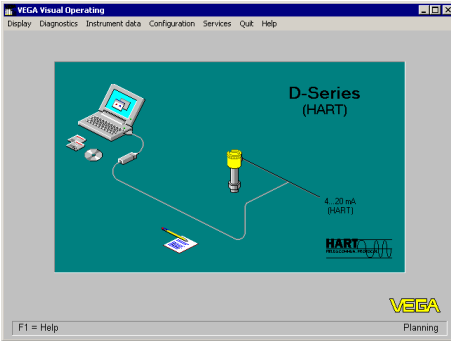

Parameter adjustment/Adjustment

In the menu "Instrument data/Parameter adjustment" you carry out all important sensor adjustments.

- Choose the menu "Instrument data/Parameter adjustment".

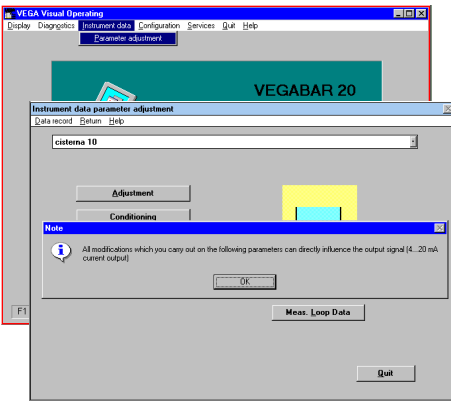

- Confirm the warning with "OK".

In the heading you now see the previously entered measurement loop name and the measurement loop description.

- Choose in the menu window "Instrument data parameter adjustment" the menu item "Adjustment".
- In the menu window "Adjustment" you click to "Min/Max-adjustment" (zero/span).

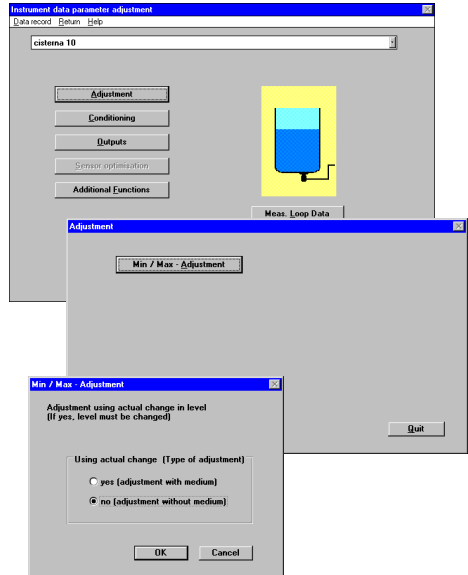

You can carry out the min./max. adjustment with or without medium. Generally you will carry out the adjustment without medium.

The adjustment can be quickly and conveniently carried out without medium, as shown in the example.

- Choose in which unit you want to carry out the adjustment.
- Enter the pressures corresponding in your application to 0 % and 100 % and push "OK".

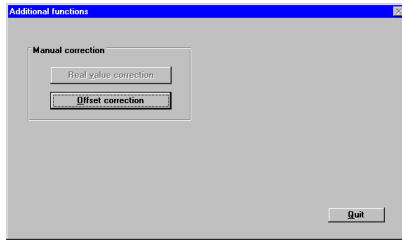
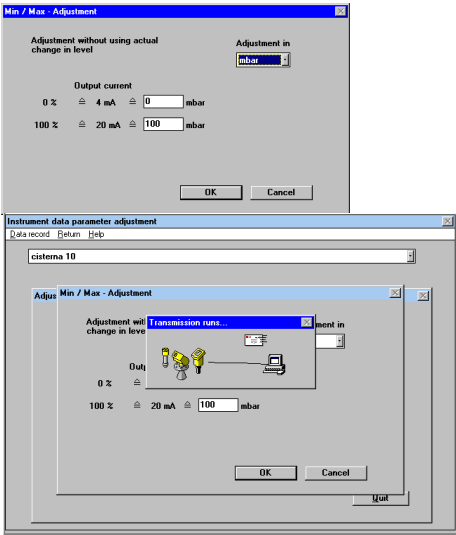

- Click to "**Offset correction**".
- When the sensor is unpressurised and in installation position, confirm the safety enquiry with "**OK**".

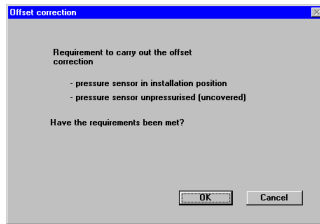

You see the actual measured value from the sensor.

- Click to "**Correct**".

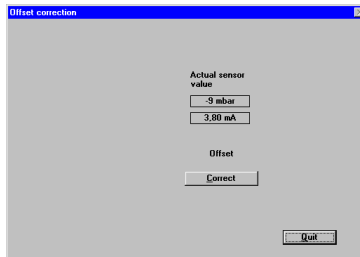

The example shows an absolute pressure transmitter with a measuring range of 0 ... 1000 mbar, with which low pressures (partial vacuum) are measured. The min. value was set to 50 mbar and the max. value (span) to 1000 mbar (i.e. the final value of the measuring range).

- Confirm your adjustments with "**OK**" and after a short data transmission to the sensor, you are again in the menu window "**Adjustment**".
- Quit all menu windows with "**Quit**" and you are again in the initial menu.

Offset correction (not possible with absolute pressure transmitters)

With this menu you can carry out a zero point correction/position correction (unpressurized sensor).

- Choose in the initial menu "**Instrument data/Parameter adjustment**" the item "**Additional functions**".

Again choose the menu "Offset correction" and you see the corrected zero value.

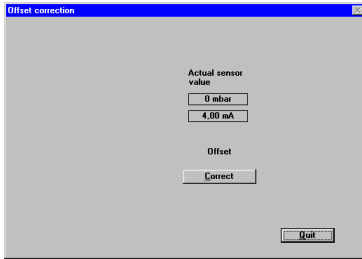

Note:

The menu item "Real value correction" enables the correction of the actual pressure by means of a reference value. This corrects the measuring characteristics in a way similar to the offset correction.

Conditioning/Linearisation

In the menu "Instrument data/Parameter adjustment/Conditioning/Linearisation" you allocated a filling quantity (volume) to the level (filling height). The correlation between level and volume is described with so-called linearisation curves.

- Click to "Instrument data/Parameter adjustment", then to "Conditioning" and finally to "Linearisation".

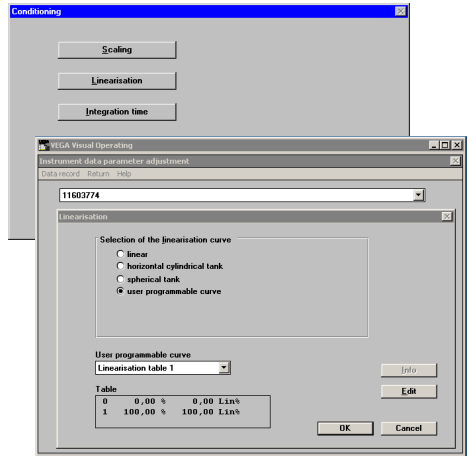
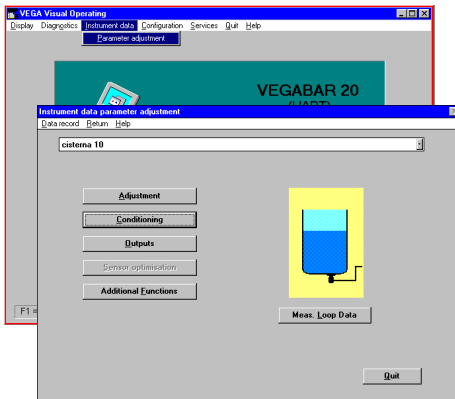

You can choose four linearisation curves: linear, horiz. cylindrical tank, spherical tank and user programmable curve.

Under "User programmable curve" you can enter your own linearisation curve as a correlation between the level in % or pressure in % (percentage value) and the volume (linearised).

- Choose "User programmable curve" and then "Edit".

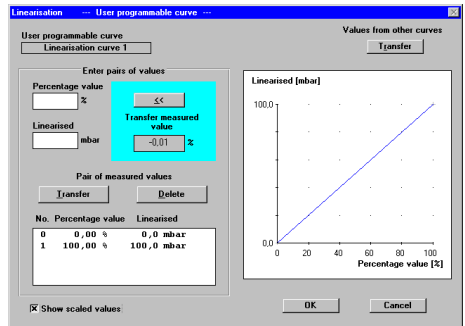

First of all, a linear correlation is displayed (the function is a straight line).

In the field "Transfer measured value" the current pressure as a percentage of the adjusted span is displayed. The measuring span has already been adjusted with the min./max adjustment. In our example this is in the range between 50 ... 1000 mbar.

The user-programmable linearisation curve is generated by index markers, consisting of the value pairs "Linearised" (volume in % or in the selected unit) and "Percentage value" (level or filling height in %).

Defining the linearisation curve by incremental filling

In the characteristics of the example (evacuated vessel), you see four index markers or value pairs. There is always a linear interpolation between the index markers.

- Click in the check box "Show scaled values", to have the selected unit of measurement displayed on the y-axis (left bottom part in the menu window).

Index marker 1 is at 0 % level or pressure (percentage value [%]), corresponding to an actual pressure of 0 mbar.

Index marker 2 is at 30 % level or pressure and 5 % filling volume.

Index marker 3 is at 70 % level or pressure and 35 % filling volume.

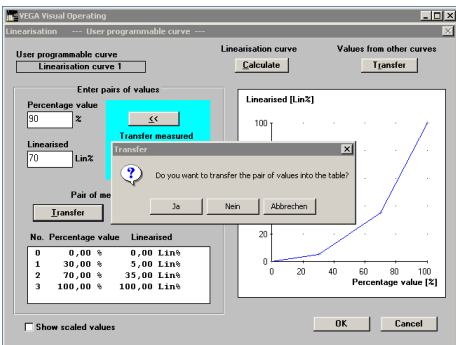

Index marker 4 is at 100 % level or pressure and 100 % filling volume (100 litres).

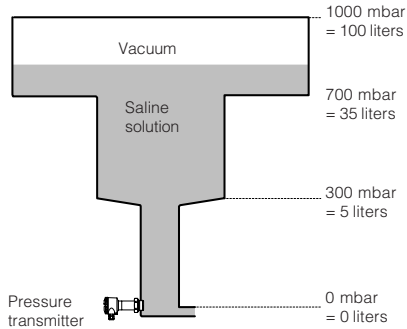

Max. 32 index markers (value pairs) can be entered.

- Quit the menu with "OK".
- Confirm the message with "OK" and your individual linearisation curve will be saved in the sensor.

Again in the menu window "Conditioning" you can enter a measured value integration with the menu item "Integration time". This is useful for fluctuating product surfaces to smooth the display and output of measured values. As a standard feature, the integration time is preset to 0 seconds.

- Quit the menu with "OK".

You are again in the menu window "Instrument data parameter adjustment".

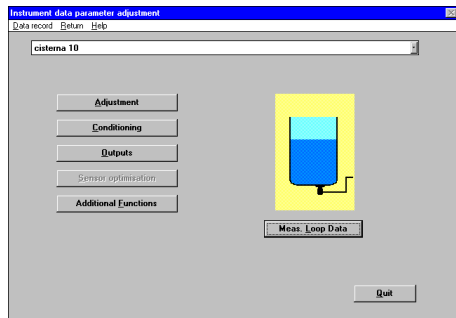

Meas. data information

- Click to "*Meas. data info*".

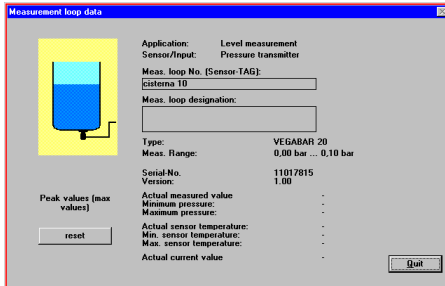

All available sensor information is displayed. With the button "*reset*" you can delete the pressure and temperature history saved in the sensor.

Backup

In the menu window "*Backup*" the sensor with its serial number is displayed. You can save the sensor data in the PC individually or in groups with all adjustments in a directory of your choice. A small text message can be added to each backup.

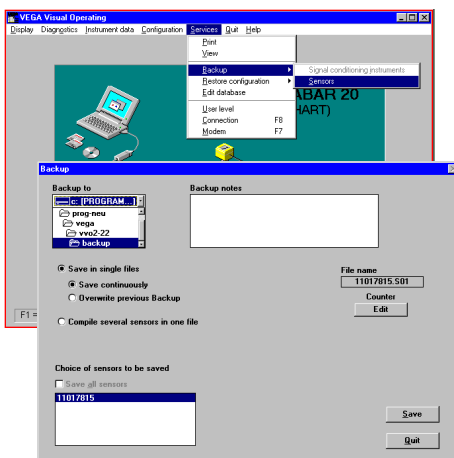

Saved sensor data can be transferred later on to other sensors.

For example, if you have a system with several of the same storage vessels and identical sensors, it is sufficient to configure one sensor and then transfer the settings to the other sensors.

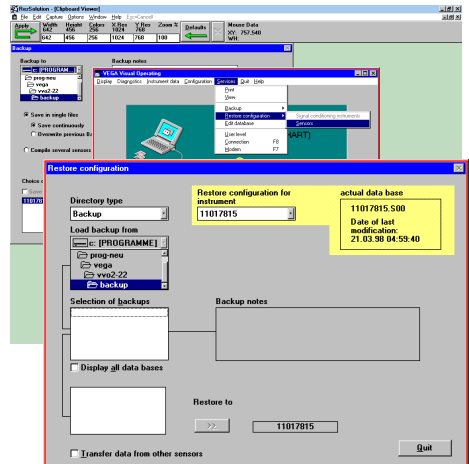

In this menu window, the actual setting (data base) with date and time of the last system configuration is displayed in the yellow window field. If you click on the serial number of the sensor from which you want to adopt the adjustments (in the yellow field), these sensor settings will be transferred to the currently connected sensor with "*Restore to*".

6 Diagnostics

Maintenance

The pressure transmitter D84 is maintenance free.

Should dismantling of the pressure transmitter (e.g. for vessel cleaning) be necessary, we recommend the use of new seals. Use only original seals from VEGA.

Remedying faults

Through continuous self-monitoring, series 80 pressure transmitters offer maximum reliability. However, if faults occur, please check the following before removing the pressure transmitter:

- the atmospheric pressure compensation (only with gauge pressure measuring ranges),
- the electrical connections.

Checking atmospheric pressure compensation

First of all, open the cover of the housing in which the atmospheric breather facility ¹⁾ is located. The displayed measured value must not change. If, however, the displayed value changes, the compensation of the atmospheric pressure does not function correctly and the measured value will be distorted. Therefore check:

- the breather facility on the housing
- the external connection housing VEGADIS 12
- the capillaries in the special housing.

Note:

The same atmospheric pressure must be acting on the breather facility and the open vessel.

Checking electrical connections

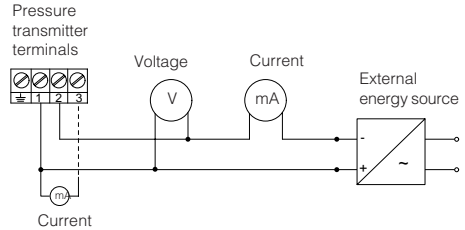

Checking the voltage

- The terminal voltage on the pressure transmitter must be at least 12 V DC.
- The terminal voltage on VEGADIS 12 must be at least 12 V DC or 17 V DC (with display).
- The supply voltage for the pressure transmitter through a VEGAMET signal conditioning instrument must be approx. 18 V DC (on VBUS 25 V DC).

Checking the current

These values are only valid for pressure transmitters with analogue signal transmission, not for pressure transmitters with digital output signal (VBUS).

- Initial current with uncovered diaphragm of the pressure transmitter: approx. 4 mA (5 mA when operated on a VEGA signal conditioning instrument)
- Measuring current during operation: 4 ... 20 mA (5 ... 19 mA when operated on a VEGA signal conditioning instrument)
- Exceeding or falling short of the specified measuring range: 20.5 mA or 3.8 mA
- Pressure transmitter defective or short-circuit: current 22 mA or 3.6 mA

¹⁾ It consists of a black plastic screwed insert with integrated filter element.

7 Instrument modification

7.1 Retrofitting the adjustment insert

Such a retrofitting can be necessary, e.g. when a pressure transmitter with factory settings must be adapted to changed measurement conditions.

Note the following retrofit procedure:

- remove the outdated terminal insert
- mount new adjustment insert
- set up pressure transmitter acc. to chapter "5 Setup"

Remove the outdated terminal insert

- 1 Separate pressure transmitter from power supply.
- 2 Unscrew cover of the connection housing or loosen the screws on the cover of the external housing.
- 3 Remove cover.
- 4 Loosen connection cables on the terminal insert.
- 5 Loosen the three screws of the terminal insert.
- 6 Remove terminal insert and pull out plug connection (to do this, bend locking nose carefully towards housing centre).

Mount new adjustment insert

- 7 Plug the connection into the adjustment insert (must snap in).
- 8 Place adjustment insert in the housing and fasten with three screws.
- 9 Connect the connection cables to the terminals.
- 10 Fasten the cover.
- 11 Reconnect the pressure transmitter to power supply.

Setup of pressure transmitter

see chapter "5 Setup".

7.2 Exchange of hygienic form seal on D84

On the hygienic connections AA, CA, LA, LB, RA, RB, TA of pressure transmitter D84, the ceramic measuring cell is radially, gaplessly sealed with a form seal. This form seal (material EPDM-FDA) can be exchanged by the user without the need of a fresh adjustment. The criteria and the time intervals for such an exchange of the seal are generally defined by the process and hygienic requirements.

Important:

Use only original replacement seals from VEGA!

Please note the following exchange procedure.

Removal procedure:

- Pressure transmitter should be unpressurized (switch off process pressure or empty vessel).
- Loosen the hexagon pressure screw (4) (width across flats, 46 mm) by turning to the left.

Note!

The process connection (6) (e.g. compression nut) must not be loosened!

- Turn the adapter (3) below the pressure transmitter housing with a wrench (with across flats, 36 mm) briefly to the left (to loosen the seal).
- Pull the complete pressure transmitter on the housing (1) out of the process connection by carefully turning to the left.
- Slightly lift the form seal (5) and loosen from the ceramic measuring cell.
- If the form seal (5) does not completely encircle the measuring cell, it must be carefully removed from the process connection.

Installation procedure:

- Place the new form seal (5) over the measuring cell (the conical end must point to the process connection!).
- Carefully insert pressure transmitter into the process connection by turning clockwise.
- Tighten hexagon pressure screw (4) (width across flats, 46 mm) (45 Nm).
- Turn the housing (1) of the pressure transmitter to the original position.

The exchange of the form seal is now finished; the removed seal must be properly disposed of.

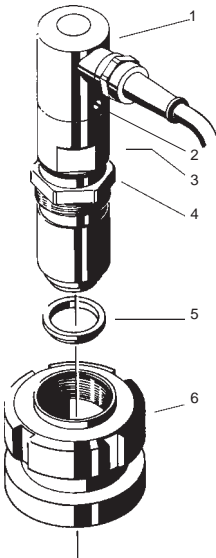

- 1 Pressure transmitter
- 2 Headless screw (prevents overwinding and must not be removed)
- 3 Adapter
- 4 Hexagon screw
- 5 Form seal
- 6 Process connection



VEGA Grieshaber KG
Am Hohenstein 113
77761 Schiltach/Germany
Phone +49 (0) 7836 50-0
Fax +49 (0) 7836 50-201
E-Mail info@de.vega.com
www.vega.com



All statements concerning scope of delivery, application, practical use and operating conditions of the sensors and processing systems correspond to the latest information at the time of printing.

Technical data subject to alterations